

Simulation and Analysis of PWM Inverter Fed Induction Motor Drive

C.S.Sharma, Tali Nagwani

Abstract— Sinusoidal Pulse Width Modulation variable speed drives are increasingly applied in many new industrial applications that require superior performance. Recently, developments in power electronics and semiconductor technology have lead improvements in power electronic systems. Variable voltage and frequency supply to ac drives is invariably obtained from a three-phase voltage source inverter. Here is used three-phase voltage source inverter which is carrier-based sinusoidal PWM (Sinusoidal PWM) with power IGBTs is described. In ac motor drives, SPWM inverters make it possible to control both frequency and magnitude of the voltage and current applied to a motor. As a result, PWM inverter-powered motor drives are more variable and offer in a wide range better efficiency and higher performance when compared to fixed frequency motor drives. Three phase voltage-fed PWM inverters are recently showing growing popularity for multi-megawatt industrial drive applications. Here open loop and close loop simulation and analysis of PWM Inverter fed Induction motor is carried out.

Index Terms— Matlab, Spwm, IGBT, Induction Motor Drive.

I. INTRODUCTION

Three phase induction motors are most widely used motors for any industrial control and automation. It is often required to control the output voltage of inverter for the constant voltage/frequency (V/F) control of an induction motor. PWM (Pulse Width Modulation) based firing of inverter provides the best constant V/F control of an induction motor. Amongst the various PWM techniques, the sinusoidal PWM is good enough and most popular that provides smooth changeover of V/F, four quadrant operation, harmonic elimination, etc in both closed and open loop applications. Three phase induction motors are reliable, robust, and highly

durable and of course need less maintenance. They are often known as workhouse of motion industries. When power is supplied to an induction motor with specified frequency and voltage, it runs at its rated speed. Many advanced semiconductor devices are available today in power electronics market like BJT, MOSFET, IGBT, etc. For this paper IGBT (Insulated Gate bipolar transistor) is used as a semiconductor device.

II. SINUSOIDAL PULSE WIDTH MODULATION

Pulse width modulation is a technique in which a fixed input dc voltage is given to the inverter and a controlled ac output voltage is obtained by adjusting the on and off periods of the inverter components. This is most popular method of controlling the output voltage and this method is termed as pulse width modulation technique. PWM is an internal control method and it gives better result than an external control methods. There are number of PWM methods for variable frequency voltage-sourced inverters. A suitable PWM technique is employed in order to obtain the required output voltage in the line side of the inverter.

A Sinusoidal Pulse Width Modulation technique is also known as the triangulation, sub oscillation, sub harmonic method is very popular in industrial applications. In this technique a high frequency triangular carrier wave is compared with the sinusoidal reference wave determines the switching instant. When the modulating signal is a sinusoidal of amplitude A_m , and the amplitude of triangular carrier wave is A_c , then the ratio $m=A_m/A_c$, is known as the modulation index. It is to be noted that by controlling the modulation index one can control the amplitude of applied output voltage.

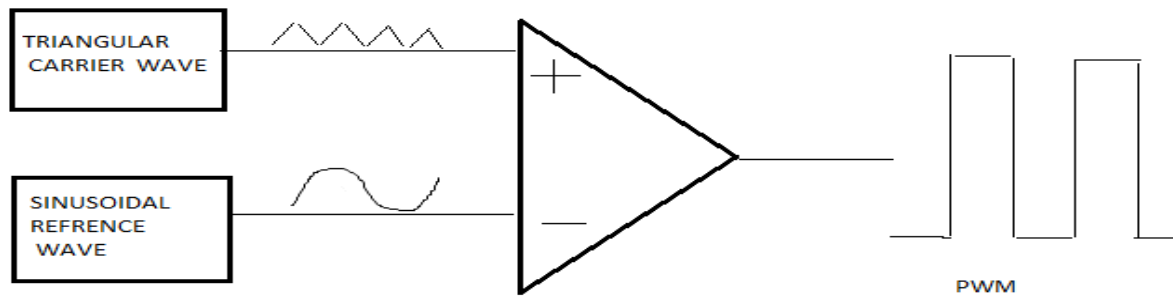

Figure 1: Sinusoidal Pulse width modulation

For wide variation in drive speed, frequency of the applied AC voltage needs to be varied over a wide range. The applied voltage also needs to be varying almost linearly with the frequency. The harmonic content in the output of the inverter can be reduced by employing pulse width modulation (PWM). Sinusoidal PWM (SPWM) is affecting in reducing lower order harmonics while varying the output voltage and gone through many revisions and it has a history of three decades. Some of the following constraints for slow varying sinusoidal voltage be considered as the modulating signal are :

1. The peak magnitude of the sinusoidal signal is less than or equal to the peak magnitude of the carrier signal. This ensures that the instantaneous magnitude of the modulating signal never exceeds the peak magnitude of the carrier signal.
2. The frequency of the modulating signal is several orders lower than the frequency of the carrier signal. For example 50 Hz for the modulating signal and 20 KHz for the carrier signal. Under such high frequency ratio's the magnitude of the modulating signal will be virtually constant over any particular carrier signal time period.
3. A three phase Sine-PWM inverter would require a balanced set of three sinusoidal modulating signals along with a triangular carrier signal of high frequency.

For a variable voltage- variable frequency (VVVF) type inverter, a typical requirement for adjustable speed drives of AC motor, the magnitude as well as frequency of the fundamental component of the inverters output voltage needs to be controlled. This calls for generation of three phase balanced modulating signals of variable magnitude voltage and frequency which it may be emphasized, need to have

identical magnitudes and phase difference of 120 degrees between them at all operation frequencies. Generating a balanced three phase sinusoidal wave forms of controllable magnitude and frequency is a pretty difficult task for an analog circuit and hence a mixed analog and digital circuits is often preferred. Simulation results are obtained using MATLAB / Simulink environment for effectiveness of the study.

III. INVERTERS

Power inverters are devices which can convert electrical energy of DC form into that of AC. Inverters can be broadly classified into two types based on their operation:

1. Voltage Source Inverters (VSI)
2. Current Source Inverters (CSI)

A current source inverter is fed with adjustable current from a DC source of high impedance, i.e. from a stiff DC current source. In a CSI fed with stiff current source, output current waves are not affected by the load. Voltage Source Inverters is one in which the DC source has small or negligible impedance. In Other words VSI has stiff DC voltage source at its input terminals. A CSI does not require any feedback diodes whereas these are required in VSI.

IV. SIMULATION RESULTS

Here we developed a DC to AC inverter fed to induction motor in Simulink / Matlab with a three phase PWM inverter controlling both the frequency and magnitude of the voltage output. For generation of PWM pulses the technique was used comparing sinusoidal control voltage (at the desired output frequency and proportional to the output voltage magnitude) with a triangular waveform at a selected switching frequency.

The harmonics in the output voltage appears as sidebands of the switching frequency and its multiples in a PWM inverter. Therefore a high switching frequency results in an essentially sinusoidal current (plus a superimposed small ripple at a high frequency) in the motor. A 3-phase squirrel-cage motor rated 3 HP, 220 V, 50 Hz, 1725 rpm is fed by a 3-phase IGBT inverter connected to a DC voltage source of 220 V. Take a look at the simulation parameters. The inverter is modeled using the "Universal Bridge" block and the motor by the "Asynchronous Machine" block. Its stator leakage

inductance L_s is set to twice its actual value to simulate the effect of a smoothing reactor placed between the inverter and the machine. The load torque applied to the machine's shaft is constant and set to its nominal value of 11.9 N.m. Observe that the rotor and stator currents are quite "noisy," despite the use of a smoothing reactor. The noise introduced by the PWM inverter is also observed in the electromagnetic torque waveform T_e . However, the motor's inertia prevents this noise from appearing in the motor's speed waveform.

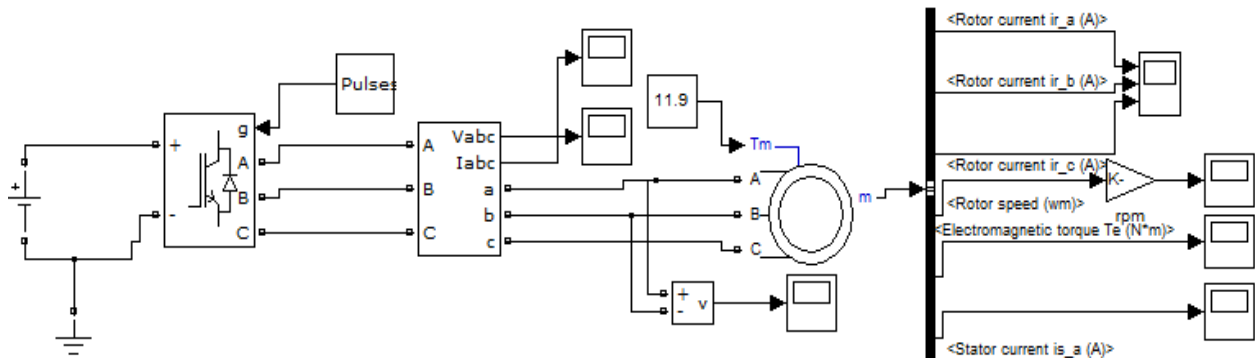

Figure 2: Simulink Model for open loop Spwm Inverter fed Induction Motor Drive

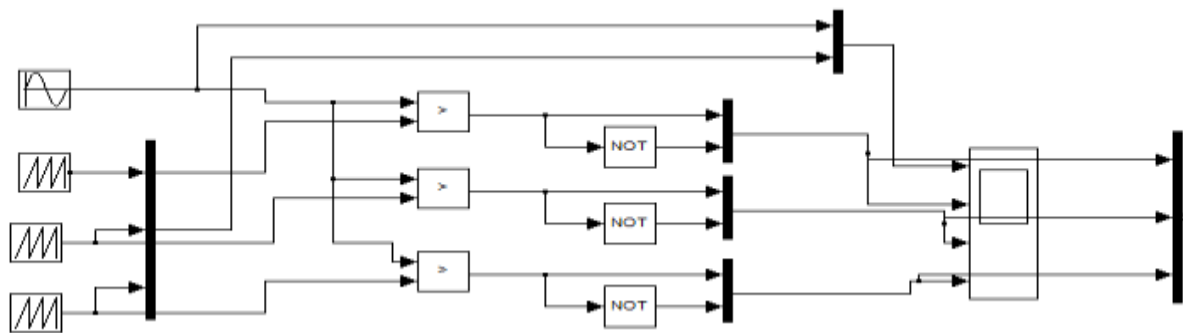

Figure 3: Spwm pulses to trigger igt

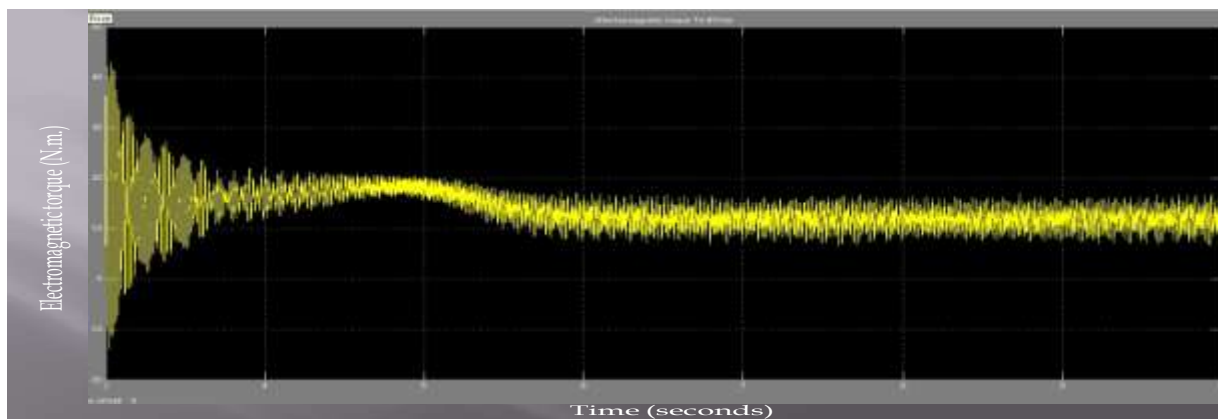

Figure 4: open loop electromagnetic torque versus time graph

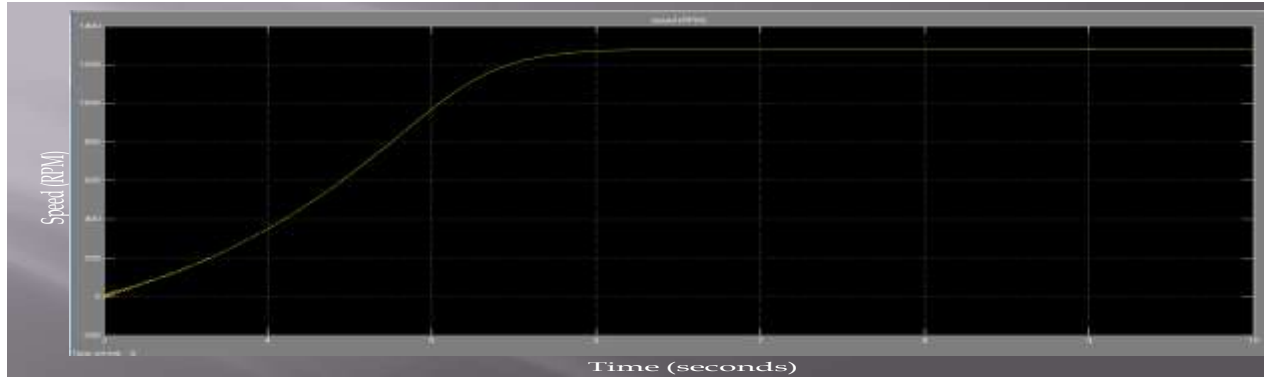

Figure 5: open loop speed versus time graph

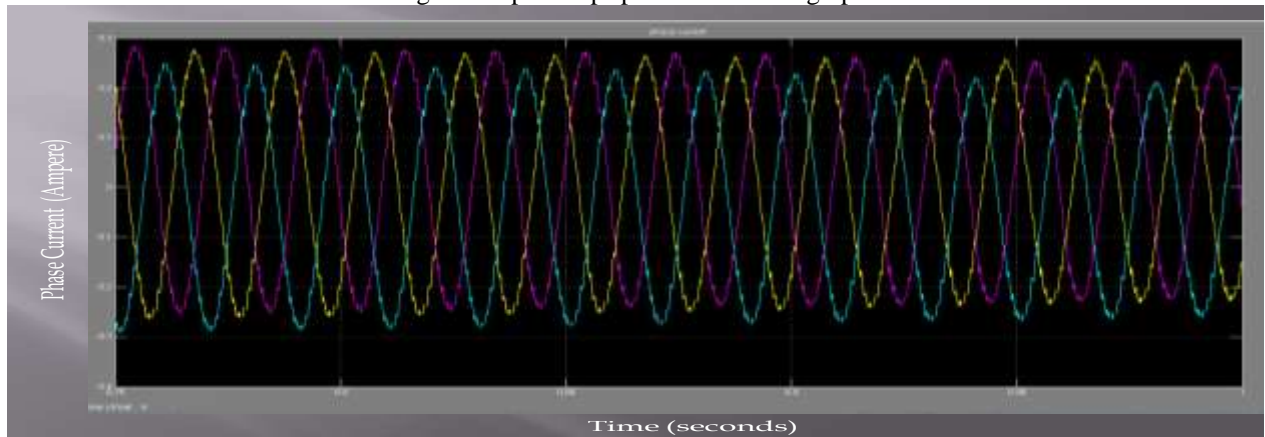

Figure 6: open loop phase current versus time graph

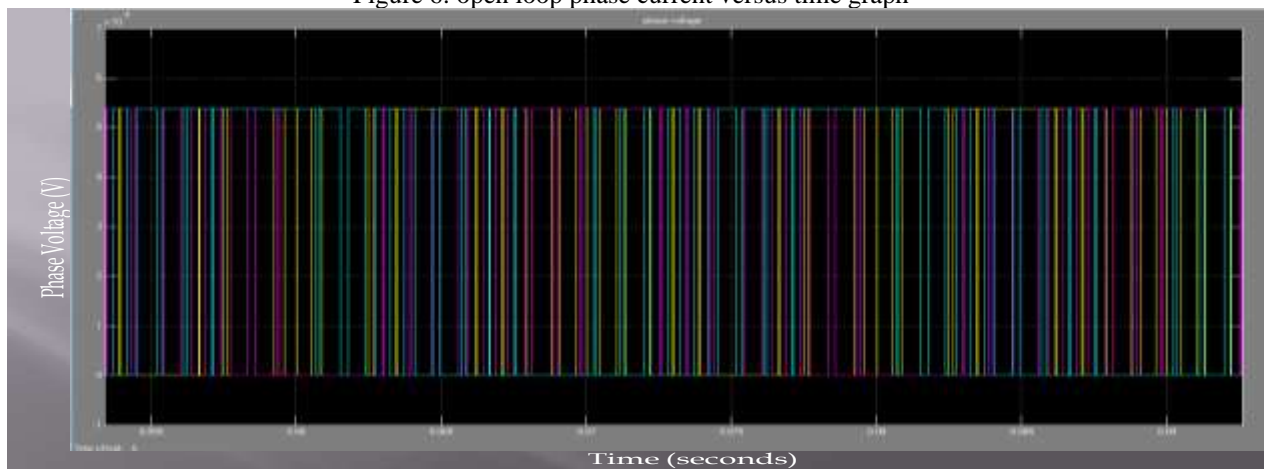

Figure 7: open loop phase voltage versus time graph

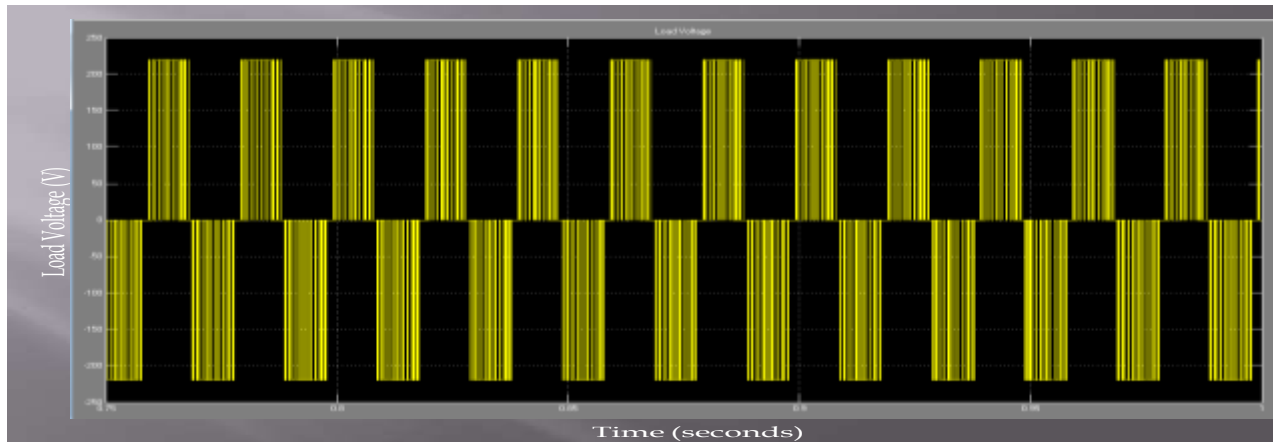

Figure 8: open loop load voltage versus time graph

MODULATION INDEX	THD OF CURRENT (%)	THD OF VOLTAGE (%)
0.4	6.09	165.57
0.5	4.46	137.00
0.6	2.97	123.44
1	2.74	68.02

Table 1: Modulation Index and its effects on THD of current and voltage in open loop system

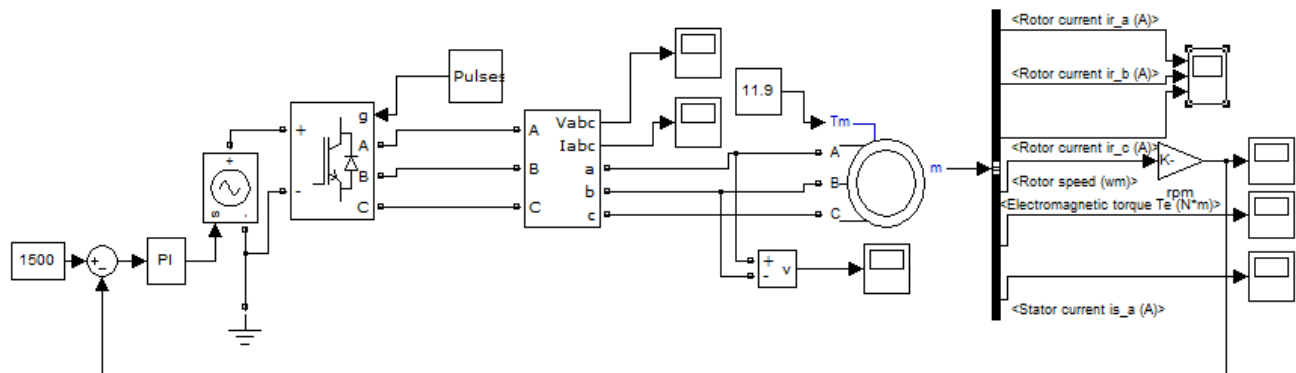

Figure 9: Simulink model for close loop Spwm Inverter fed Induction Motor Drive

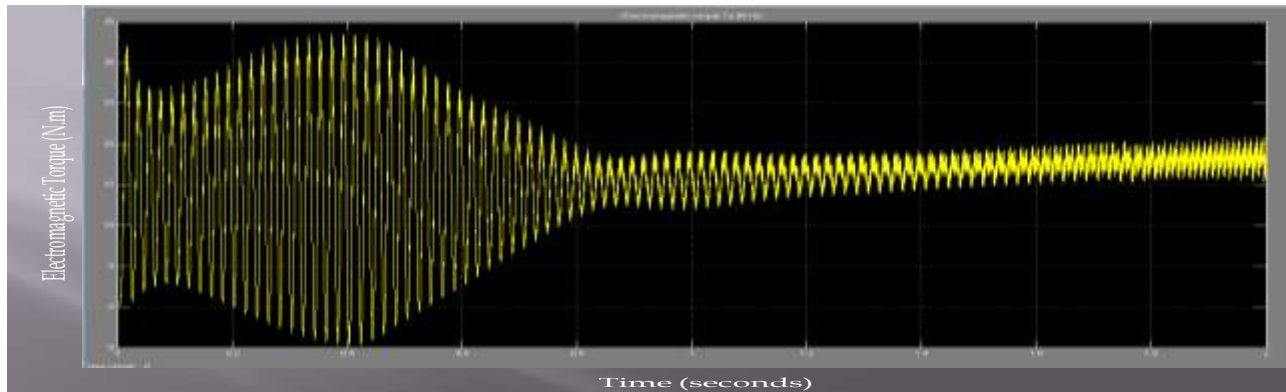

Figure 10: close loop electromagnetic torque versus time graph

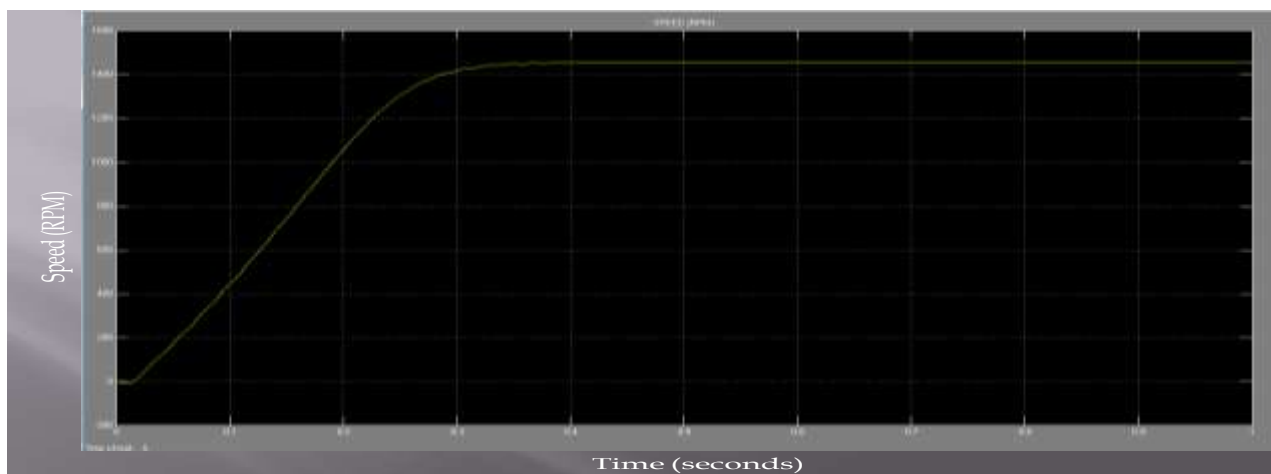

Figure 11: close loop speed versus time graph

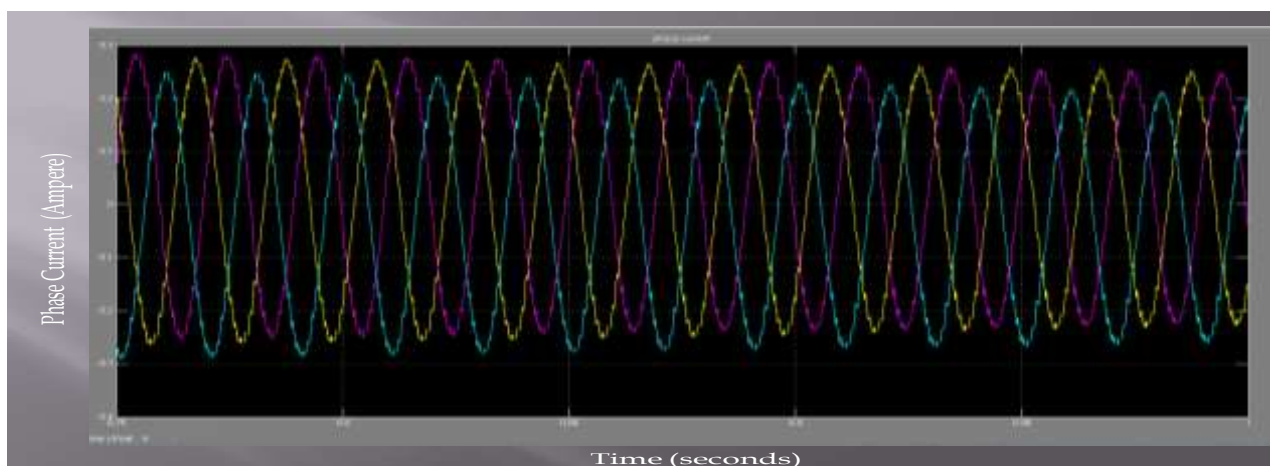

Figure 12: close loop phase current versus time graph

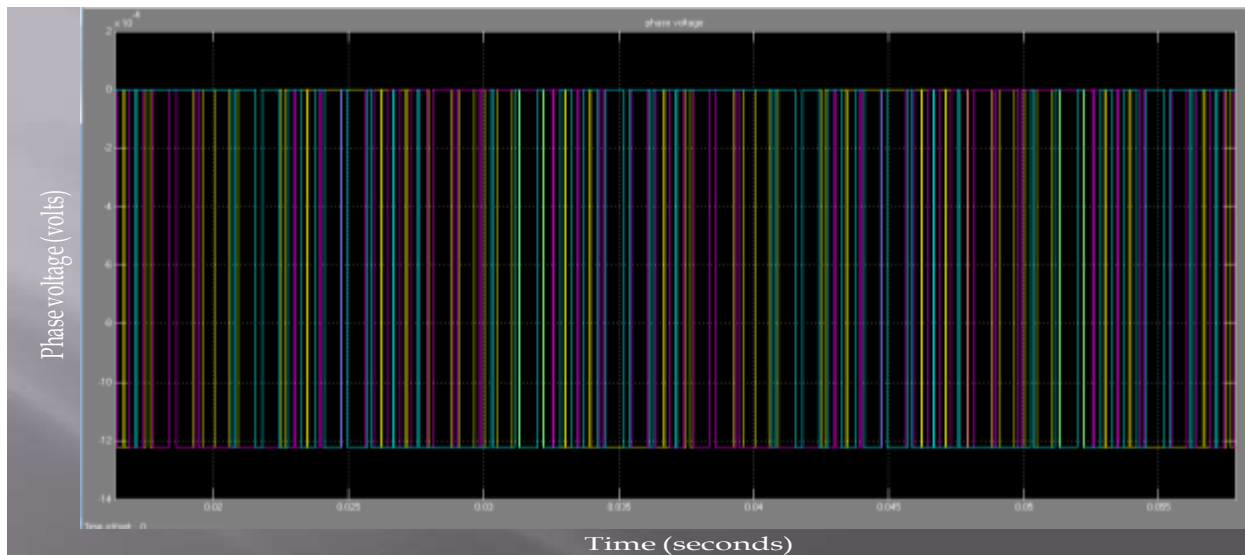

Figure 13: close loop phase voltage versus time graph

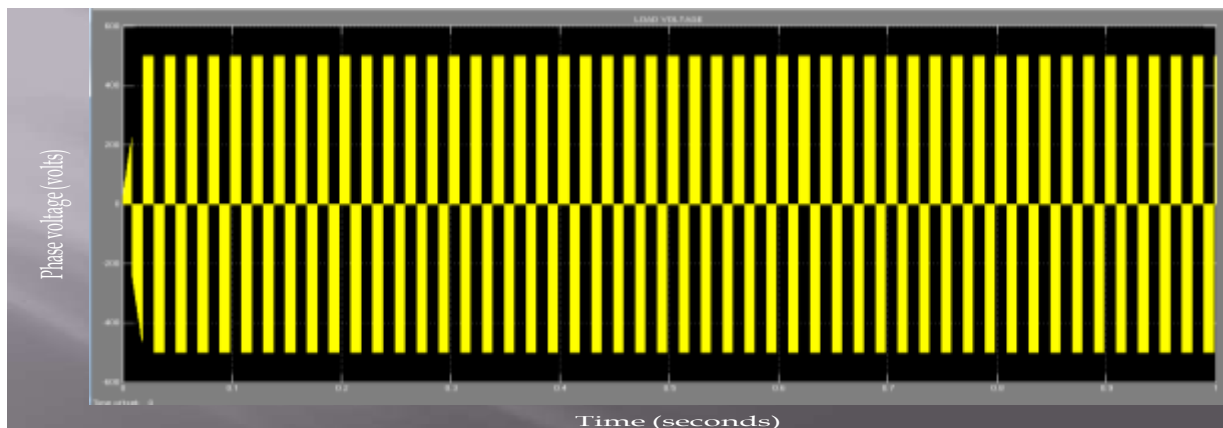

Figure 14: close loop load voltage versus time graph

MODULATION INDEX	THD OF CURRENT (%)	THD OF VOLTAGE (%)
0.4	4.58	163.84
0.8	4.05	93.63
1	3.57	68.02

Table 2: Modulation Index and its effects on THD of current and voltage in close loop system.

Here simulation and analysis of PWM inverter fed Induction motor drive is carried out. Firstly we have simulated and analyze open loop system and obtain the THD of phase current and voltage at different modulation index through FFT analysis of powergui block. Then secondly we have simulate and analyze close loop system and obtain the THD of phase current and voltage at different modulation index through FFT analysis of powergui block.

V. CONCLUSION

The main aim of this paper was to reduce THD of phase currents and voltages by varying the carrier frequency of carrier wave i.e. by varying the modulation index between 0.1 to 1.0 and probably through this paper we have fulfilled our aim to great extent. Means it has been clearly shown through results that by varying modulation index from low to high value we can minimize the THD of phase currents and voltages. The variations in modulation index also affect the speed of induction motor drive. There are fluctuations in the starting of rotor currents, electromagnetic torque but this is absent in speed. This is because of machine's inertia. This is clearly visible in scopes. In open loop system the steady state situation is reached at time $t=5$ but in close loop system the steady state situation is reached at time $t=0.15$.

REFERENCES

- [1] "Control of VSI using spwm strategy for adjustable speed motors." 14th International Research/Expert Conference "Trends in the Development of Machinery and Associated Technology" TMT 2010, Mediterranean Cruise, 11-18 September 2010.
- [2] "Simulation and comparison of spwm and svpwm control for three-phase RL load." IJREAS Volume 2, Issue 2 (February 2012) ISSN: 2249-3905.
- [3] Pankaj H Zope, Pravin G.Bhangale, Prashant Sonare, S. R.Suralkar "Design and Implementation of carrier based Sinusoidal PWM Inverter." International journal of Advanced Research in Electrical, Electronics and Instrumentation Engineering. Vol. 1, Issue 4, October 2012.
- [4] "Performance of Sinusoidal Pulse Width Modulation based Three Phase Inverter." International Conference on Emerging Frontiers in Technology for Rural Area (EFITRA) 2012

Proceedings published in International Journal of Computer Applications® (IJCA).

[5] "Modeling and Simulation of Modified Sine PWM VSI Fed Induction Motor Drive." International journal of Electrical Engineering & Technology, Volume 3, Issue 2, July – September 2012.

[6] "Carrier Pulse width Modulation for Three Phase Multilevel Inverter to Minimize THD and enhance the Performance of Induction motor." National Conference on Innovative Paradigms in Engineering & Technology (NCIPET- 2012) Proceedings published by International Journal of Computer Applications® (IJCA).



C.S.Sharma presently working as Associate Professor in Electrical Engineering at Samrat Ashok Technological Institute Vidisha (M.P) India. The degree of B.E. (Hons) secured in Electrical Engineering from Samrat Ashok Technological Institute, Vidisha in 1993 and M.E. (Hons) in Power Electronics from Samrat Ashok Technological Institute, RGPV Bhopal (M.P) in 2001. Research Interest includes Electric Drives, Power system and Power Electronics. Published more than 20 Research papers in various Journals/Conferences, which include 8 research papers in International Journals.



Tali Nagwani is a research scholar pursuing M.E in Power Electronics from Samrat Ashok Technological Institute Vidisha (M.P) India. She secured degree of B.E. in Electronics & Instrumentation from Samrat Ashok Technological Institute, Vidisha (M.P), India in 2009.