

# Electronic Notice Board for Professional College

Anushree S P, Divyashree V Bhat, Moonisha G A, Venkatesh U C

**Abstract**— Many state-of-the-art and cutting-edge universities in the world rely on wooden notice board hanging on the wall to display announcements. The overreliance of this practice in a university is still not enough to pass relevant information around as many problems are encountered. We consider the case study of professional Colleges, where information is a vital key for knowing the updates of the campus. The goal of this paper is to provide the access to notices and articles quickly not only within the college premises, also wherever and whenever they need to know. Also it looks at the development of the existing notice boards, making it run by the internet access or by local area network (LAN) so as to increase the rate at which relevant information is being disseminated to the public with no location restriction. The major strength of the Electronic Notice Board developed, which is an online web application is that, its usability is fully capable of passing relevant notices and announcements, and keeping the users updated from time to time. The user is kept updated each time the E-Notice Board is uploaded based on their preferences with respect to the departments and categories through a SMS. Also the users can view the notices and articles anytime and from anywhere by opening the web application E-Notice Board which is available online and this makes our project highly efficient and effective.

**Keywords**—E-Notice Board, College Administration, Admin, User, Alert.

## I. INTRODUCTION

A Notice Board is a place where people can leave public messages, for example, to advertise things, announce events, or provide information [1]. Notice boards are often made of a material such as cork to facilitate addition and removal of paper messages or it can be placed on digital devices such as computers, phones [2]. So people can leave and erase messages for other people to read and see. The main aim of this paper is to make information dissemination much easier in a paperless community as the world tends to graduate into that line of interaction to develop the Notice Board facility as an application, for use in college administration. This paper is about the implementation of ENB to the college administration system. The campus in focus is all the professional colleges which includes various departmental notice boards as well as other related notice boards. This work generally intends to act as a support system for the existing method by which notices are being posted in the ENB web application.

Generally innovation has come as a key factor to help to make administrative work much easier; campus executives are using new and improved versions of existing technologies to get better control of administrative activities. Campus technology leaders are dramatically enhancing data, wired/ wireless network, and device security, and are

borrowing formalized quality assurance models from the corporate world in order to end the practice of purchasing and implementing technology that just doesn't deliver as promised. The ENB is a sub type under the Virtual Learning Environments (VLE), in most case the ENB can come as a feature on a website.

The problems faced by wooden notice board could be well resolved by the implementation of our E-Notice Board application that brings an advanced means of passing notices around in the college in a much easier and efficient way. In this system the authorized user can upload the notices of different categories and departments which is recommended and approved by the higher authorities. On approval, notices can be published in the E-Notice Board. It is then intimated to the cell phones through a SMS. Respective viewer will make best use out of it. If the user wants to know more about the message received, they can open the link which is provided within the message.

E-Notice board is a web application which is engaged in providing up-to-date articles & notices and other information's for all the users associated with the particular campus or organization. The paper aims at, how the E-notice board can improve the efficiency of the student when it comes to gaining the information from the college. E-notice board is one of the applications to improve the usage of notice board of the college by making it available online. This web application involves almost all the features of online notice board, where the implementation helps the students to retrieve all the notices and articles directly through their cell phones [3]. The E-notice board system will take care of the current information's detail at any point of time. All the updates like add, delete, view are done by admin, so that user will get the updated current information through alerts. We intend to run the ENB as a program that can be viewed anywhere and anytime. For the fact that the notice board program runs on personal computers as well as mobile phones, information dissemination is efficient.

The notice board is a flat solid object placed at strategic positions making it an object on which notices and articles are being placed. In the professional college campus, notices spring up from different officers bringing reminders, warnings, advice, results, and appointments to be placed on the notice board. As these notices are being placed on the boards, some of the old notices are not removed and with time the notice boards get filled up with relevant and irrelevant notice messages, as a result of this, a person might not take caution of any new notice being displayed as the person feels he cannot go through the stress of browsing through the whole notice board searching for

relevant notices. This can be found about the notices placed in the figure of related work. It is obvious that developing ENB program would help in disseminating information much easier between different members of the college campus.

## II. RELATED WORK



**Fig 1: Professional College Notice Board**

Coming across a brief case study of the professional college, where information is a vital key for everybody's progress in and around the campus. The existing notice board system that is applied in the college works on the basis of manual updating method. A person needs to have a tab about the regulation of these notices. Spaces need to be searched in and around the notice board according to the notice that is to be displayed. This can be a tedious job, especially on the day of exam we get to see a huge crowd of students surrounding a single notice which includes the subject with room number; this might also lead the student to panic at the last go to their exam. Apart from that, at times the student would not know the updation that has occurred. Regular viewing is needed if he/she wants to know about the events. But if the notice board includes 20 plus notices being displayed at a time there are possibilities that students may not come across all of it; might miss few of them. It's impossible to accommodate all the info within the main notice board, therefore chances of displaying department related information in the departmental notice board is high, which again might remain unaware from students notice. Moreover library related information as well as placement department information shall be displayed only in their respective notice boards, wherein the students hardly visit and being unaware of important notices shall have to pay a huge penalty at the end. The absentees remain unaware of the notice that was read during their absence. Also there are limitations on space availability and time consuming, especially when it comes for searching for the relevant notice. Maintaining the archived files becomes hectic. On Regular observation only the updates will be available. Also cannot be accessible outside that physical location.

As some notices are being placed on the boards, some of the old notices are not removed and with time the notice boards get filled up with relevant and irrelevant notices. As a

result of this, a person might not take caution of any new notice being displayed as the person feels he cannot go through the stress of browsing through the whole notice board searching for relevant notices as shown in the figure 1. The implementation of ENB mainly focuses and describes the system where the Principal, Faculty or Non-academic officers, have privileges to create an account, update notice and delete an account while the user has privileges to view and download updated notices. The User (Actor) is student who intends to read notice on the ENB and request for updated Notice. ENB is connected through internet; he/she reads the updated notices from their individual locations.

## III. PROPOSED E-NOTICE BOARD

The proposed system architecture is depicted in figure 2.

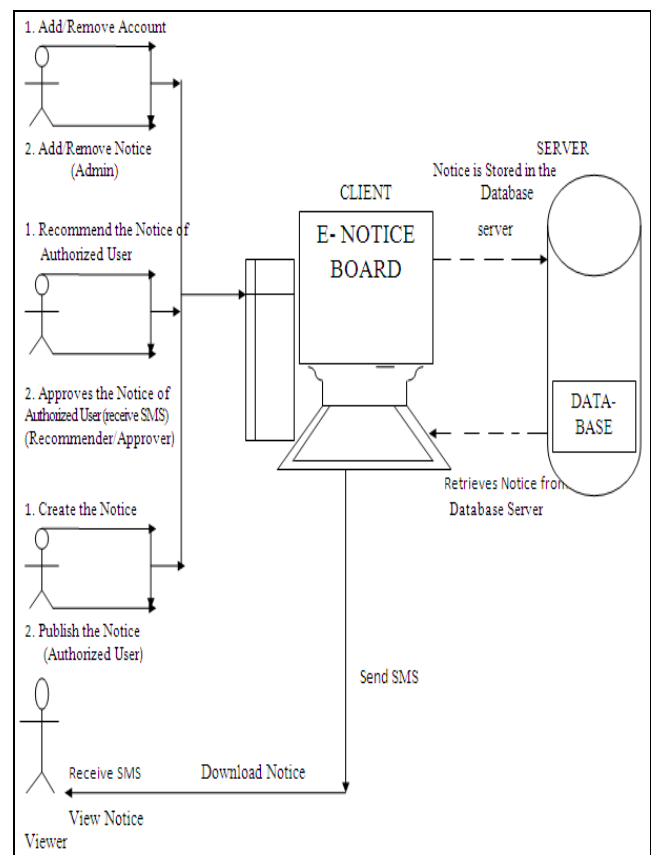

**Fig 2: Proposed System Architecture for E- Notice Board**

Architectural diagram provides a high level graphical view of the application architecture and helps to identify applications, components, databases and services. It is also described as strategic design. The architectural design of E notice board consists of admin, who has the privilege to create an account, update notice and delete an account while the recommender/approver recommend the notice of authorized user and approves the notice of authorized user. Authorized user creates the notice and publishes the notice after getting approval from the recommender/approver. Viewer has privileges to view notices and download updated notices from the authorized user. The viewer (Actor) is anybody who intends to read notice on the E-notice board and request for updated Notice. The viewer is connected to

the E-notice board through internet and checks for updated notice and also has the privilege to download the updated notice. All the notices are stored in and retrieved from the database.

Unified Modeling Language (UML) is a standardized specification language for object modeling [4]. UML is a general- purpose modeling language that includes a graphical notation used to create an abstract model of a system, referred to as a UML model. Figure 2. describes the E-Notice Board system where the Principal, Faculty, have privileges to create an account, update notice and delete an account while the user has privileges to view the respective notices as per the notifications received. The User (Actor) is anybody who intends to read notice on the ENB and request for updated Notice. The User is connected to the ENB through internet, he reads the updated notice and can also save the notice from his individual location. The following are the steps taken by the user in the ENB [5]:

- After the user has been connected to the ENB through Internet.
- Checks for updated notice and has the privilege to save the uploaded notice.
- Exit Application.

E-Notice board welcomes users with a main screen which provides all the menu options that may be selected to enter or access the other modules including the module of study. When the E-Notice Board is updated, the person who has registered will be receiving the notification. This allows for easy navigation of the notices and articles. It is an easily understandable GUI as shown in figure 3. The following modules are divided into the activities that are performed by the admin, faculty and users as listed below:

- *Admin Account Signup*
- *Faculty Account Signup*
- *Non-Academic Account Signup*
- *Student Account Signup*
- *Admin Edit/Delete*
- *Faculty Edit/Delete*
- *Update Admin Notice /Article*
- *Update Faculty Notice /Article*

#### IV. IMPLEMENTATION

The proposed system is implemented according to the architectural diagram shown. It consists of 3 parts namely, the graphical user interface, functionalities and the database management systems.

We intend to run the E-Notice Board as a program that can be viewed strictly without any specific locations. For the fact that the notice board program runs on personal computers connected by a local area network or wired or wireless networks, information dissemination is efficient. The procedure for working of E-Notice Board includes the following steps.

**Step 1:** Admin will login by giving his user name and password.

**Step 2:** Only the admin has the privilege to add and modify the departments and categories.

**Step 3:** User need to register by giving details such as: full name, login name, mobile no, password, confirm password, email id, department and category.

**Step 4:** As soon as the registration is done a mail will be sent to the respective user which includes the user name and password.

**Step 5:** User needs to subscribe by selecting their interested categories and departments.

**Step 6:** Admin has the authority to insert, update and delete the notices.

**Step 7:** Once the notice is uploaded by the admin, registered users will receive the notifications via SMS.

**Step 8:** In order to view the detailed description of the notice user need to open the link. Figure 3. depicts the sample screen shot of E-Notice Board user interface.



Fig 3: A Sample Screen of ENB User Interface

#### V. PERFORMANCE ANALYSIS AND DISCUSSION

Performance analysis is profiling which is form of dynamic program analysis that measures. Performance analysis is also shown its performance analysis also shown its performance within the existing data. In our proposed system we use SQL 2008 database. The comparison with a existing and the proposed systems are as shown in the table 1.

Since the notice board program runs on personal computers connected by the internet or LAN [6,7] , the following results are obtainable benefits: The users can get the notices being posted from anywhere in and around the campus. It acts as a medium for a quick reminder to the readers about upcoming events. The Admin and the Faculty posting the notices can post it from anywhere, as long as they have the authorized access. Notices that have expired can be referred to as they are stored in the database for a long period of time [8]. In some cases most people do not find the notices

that has been posted on the board due to the selfish interest of some people removing them for their personal use. The ENB acts as a medium where people can get and view relevant notices over time. Some of the notices being pinned on the notice board cannot be viewed clearly as they are sometimes handwritten, the notices in a ENB are being typed in hence the user can view them very clearly. The developed ENB package meets up to the standard of an effective ENB application, and is also fully capable of passing relevant notice and announcements across. The figure 5. shows the user interface of the developed ENB.

paper - based wooden notice board system. With the use of the ENB, human traffic will be reduced at notice board locations since information on notice boards can be accessed electronically on any ENB. In addition, people will be able to view multiple posted notices from anywhere and at anytime with the help of alert (SMS). The output can be displayed on large electronic board, developed as a online web application in the PC or cell phones. Security of notice is guaranteed as the admin and the faculty posting notices have an assigned key to do so. In general, the ENB will result as an improvement over the existing notice boards used in College Campus.

ID	Description	Existing Wooden Notice Board	Developed Electronic Notice Board
1	Location	On wooden boards.	On computer systems or cell phones.
2	Time consumption	Consumes a lot of time.	Consumes less time.
3	Storage	Limited storage space.	Huge database used for storage purpose.
4	Reliability	Less reliable.	Highly reliable.
5	Efficiency	Not so efficient.	Highly efficient as keeps updating through notifications.
6	Accessibility	Cannot be accessible outside physical location.	Accessible from anywhere and at anytime.
7	Availability	Once notices removed will no more be available.	Any notice is available at any point of time as stored in database for longer period of time.

**Table 1: Table for comparison of existing and developed systems**

VI. CONCLUSION

The deployment of our ENB web application brings an advanced means of passing notices around in the College Campus. It has the capability to disseminate notices in a simple and well organized manner compared to the existing

REFERENCES

[1] N. Villar, K. Van Laerhoven, H.-W. Gellersen. "A Physical Notice Board with Digital Logic and Display", (Demo). In Adjunct Proceedings of the European Symposium on Ambient, 2007.  
 [2] Jesus Ibanez, Oscar Serrano, David Garcia, and Carlos Delgado-Mata, "Memotice Board: A Notice Board with Spatio-temporal Memory", Edutainment, 2008.  
 [3] Jeff Brown, Bill Shipman and Ron Vetter, "SMS: The Short Message Service", IEEE Computer Society, pp.106-111, December, 2007.  
 [4] S. W. Ambler, "The Object Primer: Agile Model Driven Development with UML 2", Cambridge University Press, 2004.  
 [5] Michael Blaha, James Rumbaugh, *Object-Oriented Modelling and Design with UML*. Addison-2nd Edition, Pearson Education, 2005.  
 [6] F. Halsall. "Data Communication, Computer Networks and Open Systems (4th Edition)", Addison Wesley Publishers Limited, 1996.  
 [7] J. Callaghan, "Inside Intranets and Extranets: Knowledge Management and the Struggle for power", Palgrave Macmillian, 2002.  
 [8] SA Shi-xuan, WANG Shan, Introduction to Database Systems, Higher Education Press, Beijing, 2002.

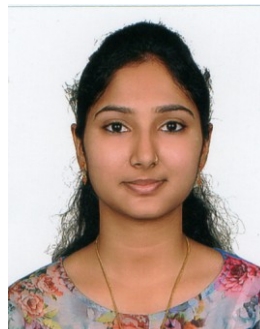

**Miss Anushree S Padmashali**, a B.E graduate in information science and engineering from K.V.G College of Engineering Sullia, VTU university belgaum, Karnataka state, India. (e-mail: anub4shree@gmail.com). Interested in the field of research and development based on database and data warehouse management.



**Miss Divyashree V Bhat**, a B.E graduate in information science and engineering from K.V.G College of Engineering Sullia, VTU university belgaum, Karnataka state, India. (e-mail: divyaa.bhat2@gmail.com). Interested in the field of research and development based on wireless networks and mobile computing.



**Miss Moonisha G.A**, a B.E graduate in information science and engineering from K.V.G College of Engineering Sullia, VTU university belgaum, Karnataka state, India. (e-mail: moonisha.mariyam@gmail.com). Interested in the field of research and development based on computer networks.