

Analysis of Grid Connected Single Phase Rooftop Photovoltaic System with MPPT

DASYAM SURYA KIRAN, M. Tech scholar & PASAM SAILESH BABU, M.Tech, Asst. Prof.,
Department of Electrical and Electronics Engineering,
Pragati Engineering College, Surampalem, Peddapuram, A.P, India.

Abstract—Nowadays renewable energy sources are widely used such as wind energy and solar energy, due to their extreme abundance. So they should be properly interfaced with the power grid with suitable devices. In this paper a system of Photovoltaic (PV) proposes attractive alternative source of generation because these can be placed near to the load centers means we can place these systems on the top of our house roofs when compared with other renewable source of generation and can be easily interfaced to distribution systems. Maximum power point tracking topology is designed to extract the maximum power from solar panel. Generally rooftop PV system consists of battery backup and supports the off grid load efficiently without interruption of power but here a NPC three level inverter is implemented for injecting the real power of the renewable power into the grid to reduce the switching power loss, harmonic distortion with single phase synchronous reference frame (SRF) theory based current controlled Pulse Width Modulation (PWM) controller to realize maximum generated power evacuation by maintaining the DC link voltage constant without battery support, low THD sinusoidal line synchronized current output, and a capacitor connected parallel to input terminal of inverter provides the limited reactive power compensation based on the unutilized capacity of the inverter. Simulation results are observed to analyze the working of rooftop PV with proposed control algorithms in grid connected mode with limited reactive power conditioning under linear load conditions.

Index Terms—Photovoltaic (PV), MPPT(Maximum power point tracking), linear loads, distribution system, THD(Total Harmonic Distortion), Pulse Width Modulation (PWM), Reactive power compensation, Synchronous reference frame (SRF), Incremental Conductance (IC),

I. INTRODUCTION

Renewable energy systems can provide clean, reliable, secure and competitive energy products and services to help meet the rapidly increasing global energy demand. In a Carbon constrained world of the future, renewable energy sources with zero net greenhouse gas emissions will have an increasingly important role to play. Being widely distributed, renewable energy sources have the potential to provide electric power, heating, cooling and vehicle transport fuels for the millions of people currently with limited or no access to them. Progress towards including the full externality costs

relating to the use of fossil fuels in comparative economic analysis of energy supply systems, together with the rate at which the costs of renewable energy technologies can be reduced as a result of mass production of energy conversion devices and greater project experience, will determine how significant the contribution of renewable energy to the global energy supply mix will become over time. It is therefore Distribution Generation (DGs) particularly single phase rooftop PV system are major research area for grid integration, with a voltage source converter and a capacitor for reactive power compensation [1]. Increase in the level of the inverter improves the power quality in the system and makes the system more stable with fewer harmonic. A NPC Three level inverter is developed and applied for injecting the real power of the renewable power into the grid to reduce the switching power loss, harmonic distortion, and electromagnetic interference caused by the switching operation of power electronic devices [2]. Since these sources have huge opportunity of generation near load terminal i.e. the source and load are very near to each other [3]. The rooftop application involving single phase DG's fed with PV source can be not only utilized for household use but the excess energy can be transferred to the grid through proper control scheme and adequate hardware. Control scheme based on instantaneous PQ theory has been presented in some literatures for single phase system [4]. Other control scheme such as synchronous reference frame (SRF) is mainly used with three phase system in which sinusoidal varying quantities are being transferred to dc quantities that provides better and precise control than PQ based control even under distorted condition of mains [5]. But SRF based control scheme can be customized for single phase which can't be utilized to get the desired dc quantity to generate required reference command. PV sources are interfaced with the grid through voltage source converters (VSC's). VSC's can be controlled either in PWM based voltage control method or hysteresis based current controlled method (HCC). HCC based controller gives fast response and better regulation but its major drawback lies with variable frequency. On the other hand the PWM based control gives fixed switching frequency that could be utilized easily for proper design of LC or LCL filters [6]. With PV sources connected at the DC side of the inverter, it is utmost essential to fetch maximum power from the source to make the system efficient. Out of different algorithm to track maximum power point (MPP) such as perturb and observe (P&O), Incremental

Conductance (IC) etc., IC based method provides fast dynamics and control over fast changing isolation condition [7] [8]. In this paper new control scheme based on SRF theory has been proposed for single phase rooftop PV grid connected system. An MPPT device is placed between the inverter and PV panel to extract the maximum power from the panel. Through the NPC Three level inverter the maximum tracked power is pumped into the grid through proper control on DC link voltage. By maintaining the DC link voltage constant during operation, is ensured the total power being generated by PV transferred across the DC bus by the inverter to the grid. Apart from active power transfer the system could be well utilized for providing limited reactive power compensation by using a capacitor connected to input inverter terminals based on available capacity of the NPC Three level inverter.

II. PV MODULE INTEGRATION WITH GRID

Fig.1 shows the block diagram of single phase grid connected PV system comprising PV panels, DC-DC converter, MPPT charge controller, capacitor, NPC Three level inverter and with linear loads.

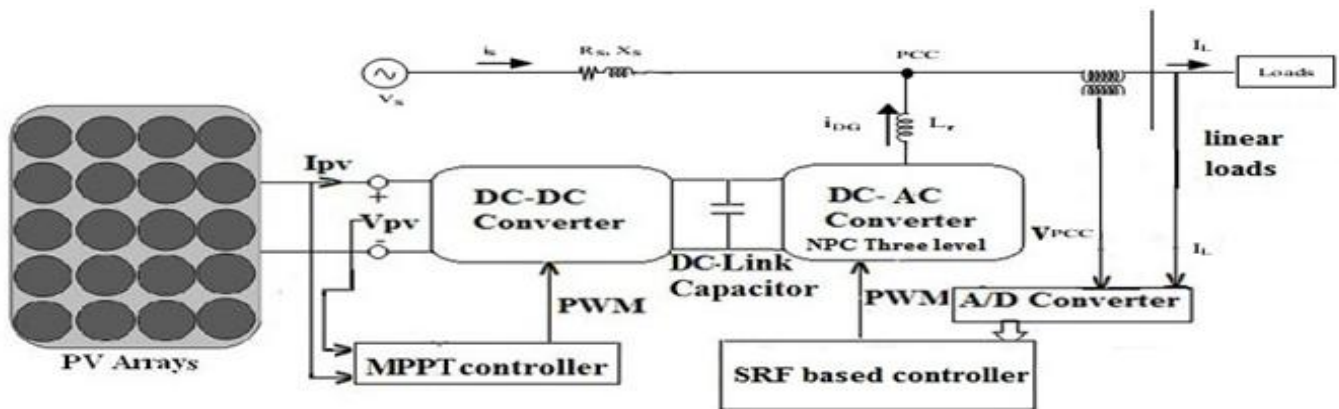

Fig.1. Block diagram of PV panel integrated to grid

The direct voltage controlled current driven NPC Three level inverter keeps the voltage across the tank capacitor constant by regulating the power evacuation through voltage control. Proper design of LCL filter at the output of inverter filters out harmonics at the PCC. The SRF theory is applied to decompose the load current to generate the reference reactive power current command. Reference for the real current component is obtained by applying PI controller on the error between measured voltage and the reference voltage.

III. MODELING OF NPC THREE LEVEL INVERTER

Figure 2 shows the NPC Three level inverter Simulink model

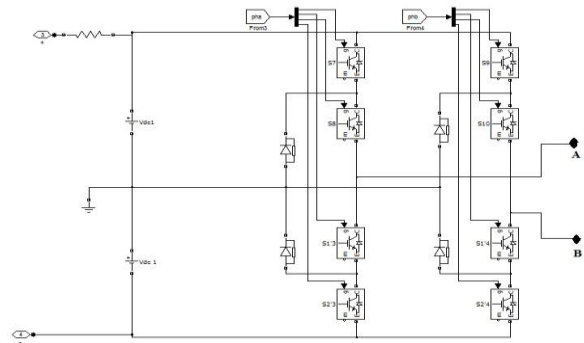

Fig.2. NPC Three level inverter model

the circuit configuration of the NPC Three level inverter applied to a photovoltaic power generation system. A NPC Three -level inverter is developed and applied for injecting the real power of the renewable power into the grid to reduce the switching power loss, harmonic distortion, and electromagnetic interference caused by the switching operation of power electronic devices.

In this paper, a NPC Three level inverter is developed and applied for injecting the real power of the renewable power into the grid.

This NPC Three level inverter is configured by a dc capacitors and full-bridge inverter. The NPC Three level inverter generates an output voltage with NPC Three levels and applies in the output stage of the renewable power generation system to generate a sinusoidal current in phase with the utility voltage to inject into the grid.

Advantages of NPC Three level inverter

The NPC topology offers the following advantages:

- Reduced switching losses:

Only the half the voltage have to be switched this half's also the switching losses in the transistor. In the shown NPC topology we are able to use 600V components instead of 1200V types. On top on that are in 600V technology much faster components available than in 1200V technique. This will lead to further reduction of the switching losses.

- Smaller output current ripple:

The NPC topology will have lower ripple in the output

current and half of the output voltage transient. This will reduce the effort for filtering and isolation in the filter inductor.

- The total +/- supply voltage is shared:

The DC voltage is divided in a positive and in a negative voltage which supports the serial connection of DC-capacitors without problems of leakage compensation.

IV. MATHEMATICAL MODELING OF PHOTOVOLTAIC MODULE

General mathematical description of I-V output characteristics for a PV cell has been studied for over the past four decades. The PV cell is usually represented by the single diode model. The single diode equivalent circuit of a solar cell is as shown in Figure3.

PV cell that is duly constructed with a parallel current source to the diode, a shunt resistor R_p , a series resistor R_s and a load resistor R_L . The basic equations [2,3] from the theory of semiconductors that mathematically describes the I-V characteristics of the ideal photovoltaic are given as follows:

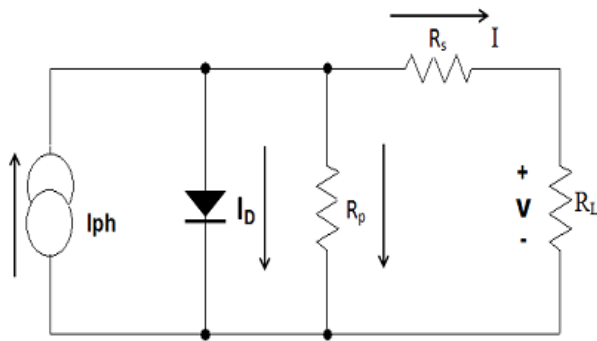

Fig.3. PV single diode model

$$I = I_{ph} - I_D \quad (1)$$

where,

$$I_D = I_o \exp\left(\frac{qV}{akT} - 1\right) \quad (2)$$

$$I = I_{ph} - I_o \exp\left(\frac{qV}{akT} - 1\right) \quad (3)$$

In the above equations, I_{ph} represents the current generated by the incident light, I_D is the diode current and I_o is the reverse saturation current of the diode, q is the electrical charge, k is the Boltzmann constant, T is the temperature of the p-n junction, and 'a' is the diode ideality factor (constant). For an ideal photovoltaic cell, assuming there are no losses/leakages, this ideal cell can be modeled as a current source in parallel with a diode. Improving the PV cell model includes the effects of series and shunt resistance, and these are presented here in this paper.

To make an entry into simulation of a single diode PV cell Model, it becomes customary to have a look at the accessories

used along with the diode, namely, a current source in parallel, a shunt resistor for current flow and a series resistor implying the internal resistance for the current flow. The various parameters that are included in this model are: short circuit current, open circuit voltage, values of shunt and series resistor and finally, the ideality factor. The ideality factor has been taken to be unity here, even though it is a function of the voltage across the device. The two other important parameters that influence the characteristics of solar cells are the Solar irradiance, an instantaneous quantity describing the rate of solar radiation (power) incident on a surface and Solar isolation referring to the amount of solar energy received on a surface.

Substituting for thermal voltage $V_T = kT/q$,

The expression for the photovoltaic current is given by:

$$I = I_{ph} - I_o \left[\exp\left(\frac{V + IR_s}{V_T}\right) - 1 \right] - \left(\frac{V + IR_s}{R_p} \right) \quad (4)$$

and expression for voltage is given by

$$V = I_{ph} \cdot R_p - I \cdot R_p + I_o \left[\exp\left(\frac{V + IR_s}{V_T}\right) - 1 \right] - I \cdot R_s \quad (5)$$

V. CONTROL STRATEGY

In the proposed system the 3 phase SRF based theory is modified for single phase system. The heart of the control scheme lays with correct estimation of phase voltage though phase locked loop (PLL), which is used for generation of unit template vectors. The output $\sin\omega t$ of the PLL will be in phase with single phase voltage at PCC. For applying SRF theory to single phase system, phase voltage or current is assumed as alpha (α) component in α - β frame (stationary frame of reference), and β component is obtained by introducing phase delay of 90° to alpha components as shown in Fig. 3. Using modified SRF theory both DG and load currents are transformed into d-q components and passed through low pass filter (LPF) to obtain only DC components corresponding to fundamental frequency as shown in Fig. 3. For such synchronized modified SRF theory based transformation I_d and I_q components corresponds to real and reactive power components respectively.

In the photovoltaic based grid connected system it is important to extract MPP tracked power for proper operation and to avoid panels heating due to under utilization. To guarantee this, constant DC bus voltage is required to be maintained across DC link capacitor, and reference current is generated to obtain the command voltage reference for PWM control of the inverter as shown in Fig. 4. The control forces the output current of inverter to closely follow the reference current. The DG's main task is to send maximum power to the grid via NPC Three level inverter. In the event of varying isolation or during low

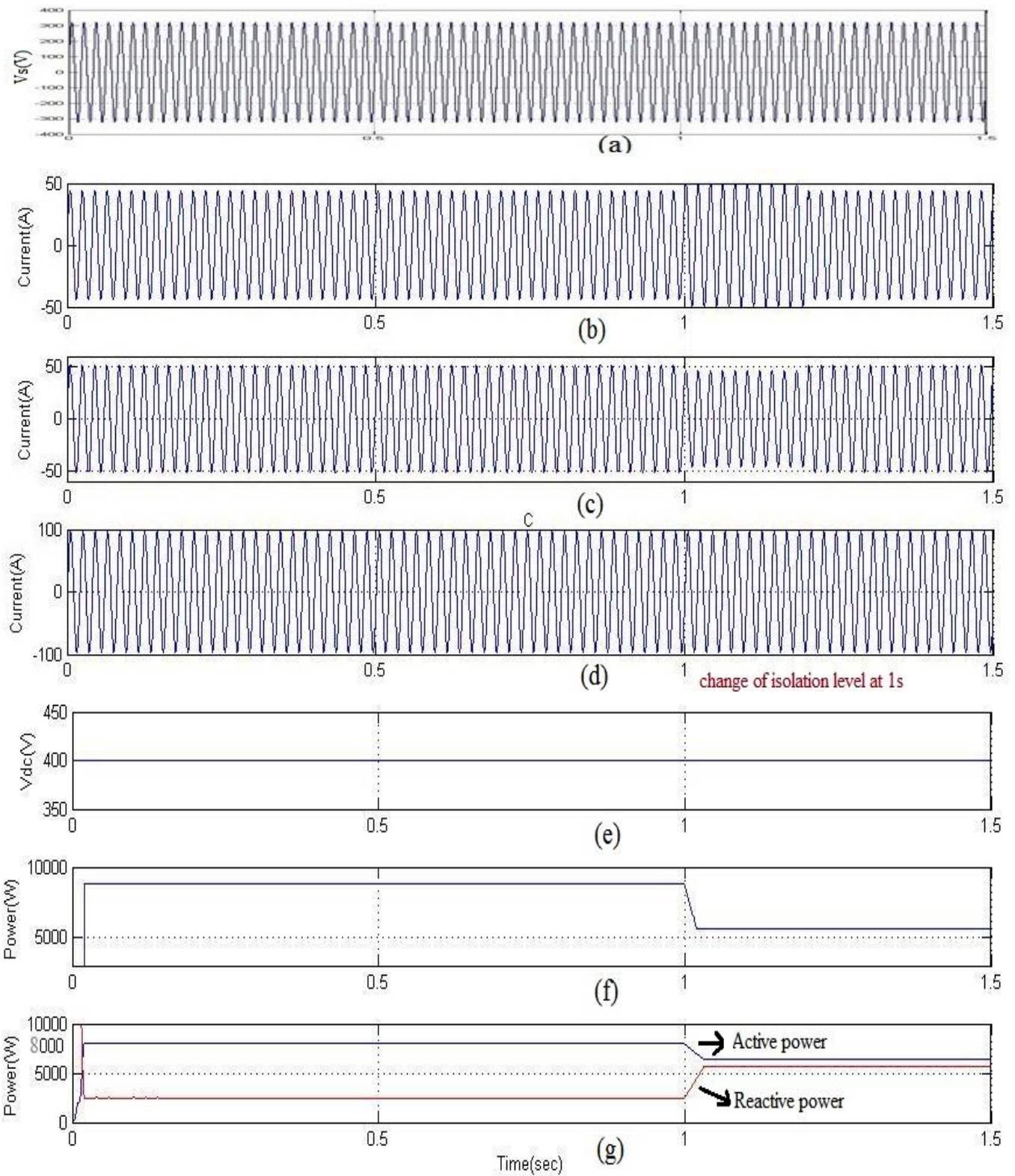

Fig.6. Dynamic response of single phase rooftop PV system

- (a) Voltage at PCC
- (b) Source current from grid
- (c) VSC current
- (d) Load current
- (e) DC link Voltage
- (f) MPPT power
- (g) Active & Reactive power of VSC

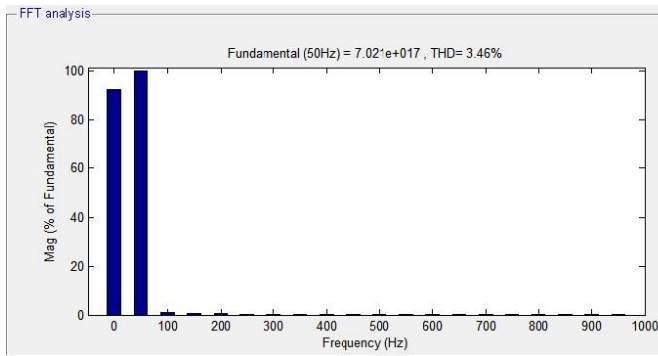

Fig.7. Total harmonic distortion of inverter current

Table 2

	Proposed system		
	High intensity (0-1sec)	Low intensity (1-1.5sec)	
		1-1.2s	1.2-1.5s
Inverter current	52A	46A	52A
Mppt power	8.77kw	5.63kw	
Active and reactive power (P,Q)	8.0kw	6.4kw	
	2.5kvar	5.6kvar	
Total harmonic distortion(THD)	3.46%		

VII. CONCLUSION

The simulated result of the proposed topology clearly demonstrates the ability of the implemented system both for linear load conditions. MPPT made the system to extract maximum power from the solar panel and provided limited reactive power compensation with grid connected mode. The MPPT controller tracked the power very quickly even under step change of isolation, and the current controlled PWM controller inject adequate generated current for self support of capacitor at DC bus and thereby providing storage less operation. The proposed SRF based approach enable the control for providing limited compensation of reactive power depending on available unutilized capacity of inverter. The NPC Three level inverter injected the real power of the renewable source into the grid to reduce the switching power loss, harmonic distortion, and electromagnetic interference caused by the switching operation of power electronic devices due to which total harmonics distortion is very low in the system. Hence the above analysis proved that this implemented topology suits for rooftop PV system and works with high efficiency.

REFERENCES

[1]. Vishal verma, Amritheskumar, “Grid Connected Single Phase Rooftop PV System with Limited Reactive Power Supply”. IEEE Trans.Power& Energy control.,vol 28

no.1, Feb 2013.
 [2]. Yacoubi, L.,Al-Haddad, K.,Fnaiech, F., DessaintL.-A.“Adaptive Nonlinear Control Law Applied To A Three-Phase Npc Boost Rectifier Operating Under Severe Conditions”, IEEE Conf.Power Electronics Specialists Conference, vol. 2, Feb 2002.
 [3]. Velasco de la Fuente, D. ;Garcera, G. ; Figueres, E. ; Guacaneme, J.“Reconfigurable control scheme for a PV microinverter working in both grid connected and island modes,” IEEE Trans. Industrial Electronics, 2012.
 [4]. JmjunLiu ;Jun Yang ;Zhaoan Wang "A New Approach For Single-Phase Harmonic Current Detecting And Its Applicationin in a Hybrid Active Power Filter," IEEE conf., 1999.
 [5]. B. Singh, V. Verma, “,Selective compensation of power-quality problems through active power filter by current decomposition”IEEE Trans. Power delivery., vol. 23, no. 2, April 2008.
 [6]. GuohongZeng; Rasmussen, T.W.; Lin Ma; Teodorescu, R., “Design and control of LCL-filter with active damping for Active Power Filter,” IEEE International Symposium on Industrial Electronics, pp. 2657-2562, 2010.
 [7]. S.Mekhilef, "Performance of grid connected inverter with maximum power point tracker and power factor control," International Journal of Power Electronics, vol. 1, pp. 49-62, 2008.
 [8]. S.MekhFemia, N.; Petrone, G.; Spagnuolo, G.; Vitelli, M., “A Technique for Improving P&O MPPT Performances of Double-Stage Grid-Connected Photovoltaic Systems,” IEEE Trans. Industrial Electronics, vol. 56, pp. 4473-4482, 2009.
 [9]. M. G. Villalava,j. r. Gazoli,E. Ruppert F., “Modelling and circuit –based simulation of Photovoltaic arrays” Brazilian Journal of Power Electronics,vol 14,no.4,pp. 35-45, 2009
 [10]. B. Crowhurst, E.F. El-Saadany, L. El Char and L.A. Lamont "Single-Phase Grid-Tie Inverter Control Using DQ Transform for Active and Reactive Load Power Compensation," IEEE conf.,PECON, Malaysia, 2010.