

Power Quality Problem Mitigation in a Hybrid Power System with STATCOM and Active Filter

Firoz Sarkar, R. Ramya,

Abstract— The paper represents basic power quality problems as Voltage distortion, Harmonics and voltage sag in a wind and solar based hybrid power system. Because of power quality problems are everywhere, it should be mitigate for better power quality. Voltage sag is the most common power quality problem in power system. If we consider a hybrid power system power quality problems is always there. In a wind and solar hybrid power system the most common power quality problems is voltage distortion, harmonics and voltage sag. In this paper is shows that how to mitigate the power quality problems by using static synchronous generator and active filter. This will help to connect more numbers and different types of power system connected to grid with better power quality. Another PV system is used as source of STATCOM for better usage of non-conventional resource.

Index Terms— Photovoltaic (PV), Solar farm (SF), Voltage source inverters (VSI), Wind energy system (WES), Doubly-fed induction generator (DFIG), Induction generation (IG), Static synchronous compensator (STATCOM), Distributed generation (DG), Active filter (AF),

I. INTRODUCTION

IN this era the major challenge for utilities is grid integration of more or increasing number of wind energy based distributed generators (DG). The main concern is reliability of the system as the increasing number of non-conventional energy resources based generation system connecting to grid. The photovoltaic (PV) solar system produces power close to rated maximum power required as per requirements. Solar energy system acts as a source of STATCOM. Taking a non-renewable source as a voltage source inverter implies that the system does not require any extra energy to regulate the grid voltage during fault. DFIG based wind turbines (WTs) with variable speed can offer increased efficiency in capturing the energy from wind from a wider range of wind velocity, as well as better power quality. In recent days the preferable configuration for wind turbine is Doubly Fed Induction Generator (DFIG).

With the various development of distribution generation system, the non-conventional energy resource as wind and PV solar system become the source of great amount energy. In PV system the current control is used for application of real and

reactive power control. Production of wind energy system now days hundreds even thousands of megawatt power. Due to variable velocity of wind DFIG generation is used in the system. The basic model diagram of the system is shown in fig1. It is the single line diagram of the PV solar STATCOM connected to the PCC in the grid connecting DFIG wind energy system. The main purpose of the system to control power quality problems using non-conventional source for reducing extra cost and power losses as well as more reliability in faulty conditions.

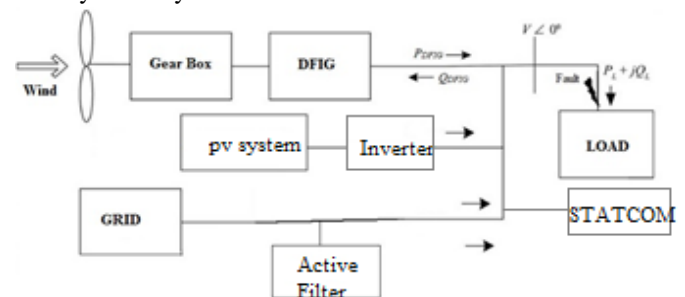

Fig.1 Hybrid System connected to the system with AF & STATCOM

II. PV SOLAR SYSTEM

Solar power generation is the conversion of light energy to electric energy. Sunlight or photon can be converted directly into electric power using photovoltaic (PV), or even easier with the concentrating solar power (CSP) as heat conserve, which generally focuses the photon energy to water at its boiling point which can be used to generate power. Photovoltaic (PV) were early used to generation as a single solar cell to small household stuffs powered by photovoltaic (PV) arrays. A PV solar cell is a device that converts light/photon into electric current using the effect of photoelectric. The photovoltaic power (PV) system, or PV system array produces direct current (DC) power which dependent with the sunlight's photon intensity. In practical use this is usually need conversion to certain require voltages as alternating current (AC) voltages by using an inverter. Many solar cells are connected inside the modules. All modules are wired together to form solar arrays, then all tied to an inverter, which produces the power at desired voltage for DC and for AC, it is voltage as well as the required frequency and phase.

Manuscript received April, 2015.

Firoz Sarkar, PG Research Scholar, SRM University Kattankulathur, Chennai, Tamil Nadu, India, +91-9851872395

R.Ramya, Assistant Professor, SRM University Kattankulathur, Chennai, India,

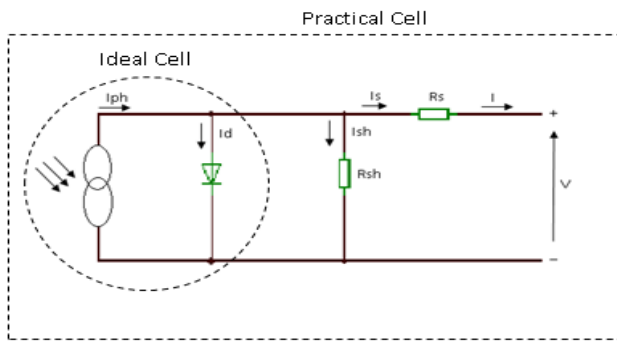

Fig.2 An ideal PV cell

By connecting solar cell in series and parallel can be created solar module and solar array as our required output. A buck-boost converter and inverter matches the required output voltage as per grid voltages.

III. ACTIVE FILTER AND STATCOM

In this paper STATCOM and Active Filter required power is supplied by extra power source. As a multilevel (Three level) STATCOM used in this system the power required 120V system used in three places as source of STATCOM. As STATCOM and Active Filter source 40V DC V_{stat} connected to the point of common coupling (PCC) to regulate the grid voltage.

the equations for source of filter and STATCOM are:

$$I = I_{ph} - I_d - I_{sh}$$

$$I_{ph} = [I_{scr} + K_i(T - T_r)] \left(\frac{s}{s_r}\right)$$

$$I = I_{ph} - I_d = I_{ph} - I_0 \left(\exp\left(\frac{qV}{nKT}\right) - 1\right)$$

$$I_d = \left[\exp\left(\frac{V_d}{V_t}\right) - 1 \right] = I_0 \left[\exp\left(\frac{V_d}{V_t}\right) - 1 \right]$$

The STATCOM connected to the PCC by a linear transformer across the load. The STATCOM supplies the current I_{stat} to the PCC to grid. Where V_{pcc} is synchronized with PCC voltage as well as WES voltage. Above mentioned equations are for designing PV solar cell and desire outputs of the PV solar system. Here STATCOM and AF used controller to check pulses with triangular saw tooth wave and generate pulses according to the waveform.

IV. DOUBLY-FED INDUCTION GENERATOR

There are four main stages to design a DFIG wind turbine. Those are turbine model, generator model, drive train model, and controller. DFIG wind turbines are consisting of a wound rotor induction generator to the system and an AC/DC and DC/AC IGBT-based PWM converter to control the output. The stator winding of the generator is connected directly to the 50 Hz grid connection while the rotor side is fed at variable frequency through the AC to DC and DC to AC converter. The DFIG from WES technology allows extracting maximum energy from the wind compare to other IGs for low wind speeds by utilizing the turbine speed, when minimizing the mechanical stresses on the wind turbine during gusts of wind flow. The optimize turbine speed producing maximum mechanical energy for a given wind speed is proportional to

the other output of wind speed. One of the better advantage of the DFIG technology is the key for power electronic converters to absorb or generate reactive power, for this eliminating the need for installing capacitor banks as in the case of squirrel-cage induction generator.

The doubly-fed generator rotors are typically wound with 2 to 3 times the number of turns of the stator winding. That explains the rotor voltages will be higher and currents respectively lower than the stator voltage. It implies that the typical $\pm 30\%$ operational speed range around the synchronous speed, the rated current of the converter is accordingly very lower what leads to a lower cost of converter the system. The main drawback is that controlled operation outside the operational speed range is impossible because of the higher than rated rotor voltage of the system. And for further analysis, the voltage transients due to the grid disturbances (three- and two-phase voltage dips, generally) will also be magnified and checked. In order to prevent very high rotor voltages - and high currents resulting from these voltages - from damaging the IGBTs and diodes of the converter system, a protection circuit (called crowbar) is used. In Fig.3 the crowbar will short-circuit the rotor windings through a small resistance while excessive currents or voltages are detected in the system. In order to be able to continue the operation as quickly as possible an active crowbar has to be used to rotor side.

The stator part of the generator is directly connected to the AC mains, where the wound rotor is fed from the Power Electronics Converter via slip rings to allow DFIG to operate at a variety of speeds in response for changing wind velocity. The basic concept is to interpose a frequency converter between the variable frequency IG and fixed grid frequency. As the DC capacitor linking stator- and rotor-side converters allows the storage of power from induction generator for further generation of wind power. To achieving the full control of grid current, the DC-link voltage must be boosted to the level of 18 or higher than the amplitude of line-to-line voltage of the grid. The slip power can flow in both directions, i.e. to the rotor from the supply and from supply to the rotor and hence the speed of the machine can be controlled from either rotor- or stator-side converter in both super and sub-synchronous speed ranges. Below the synchronous speed in the generating mode and above the synchronous speed in the generating mode, rotor-side converter operates as a rectifier and stator-side converter as an inverter, where slip power is returned to the stator. Below the synchronous speed in the generating mode and above the synchronous speed in the motoring mode, rotor-side converter operates as an inverter and stator side converter as a rectifier, where slip power is supplied to the rotor.

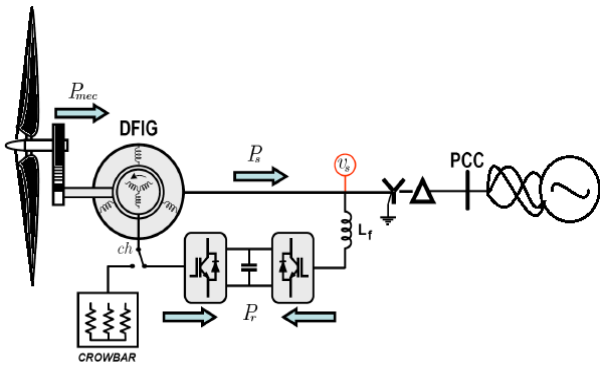

Fig.3 The doubly-fed induction generation

The AC to DC and DC to AC converter is divided into two components: the rotor-side converter (RSC) and the grid-side converter (GSC). The Voltage-Sourced Converters (VSC) going to forced-commutated with power electronic devices (IGBTs) to synchronize an AC voltage from a DC voltage source as per requirements. A capacitor bank connected on the DC side acts as the DC voltage source of the rotor side. A coupling inductor L_f is used here to connect grid side converter to the main grid. The three phase winding is connected to rotor side converter by slip rings and brushes and the three-phase stator winding, which is directly connected to the grid.

V. MULTILEVEL STATCOM

STATCOM is nothing but a voltage source converter. It is mainly used for mitigating power quality problems like voltage swell, voltage sag, interruption etc. A generating component generates pulse to compare to main signal and controller sending the output voltage according to the pulse. In this model PI controller is used as controller. In this paper three level STATCOM is used.

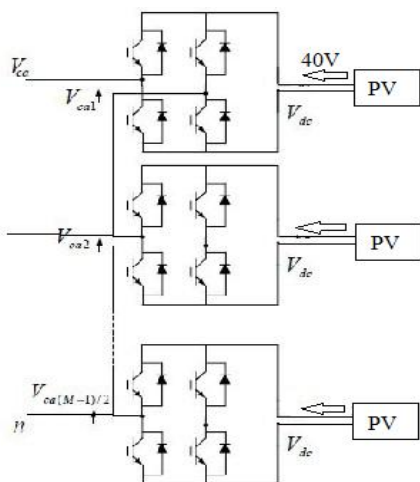

Fig.4 Three level STATCOM

VI. ACTIVE FILTER DESIGN

An active filter is a type of analog electronic filter that uses active components such as an amplifier. Amplifiers included in a filter design can be used to improve the performance and predictability of a filter, while avoiding the need for inductors.

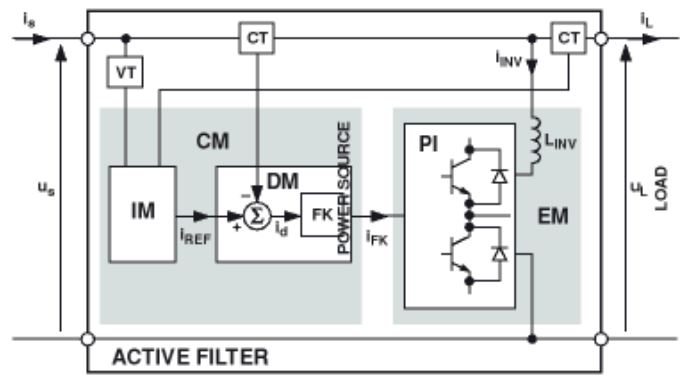

Fig.5 Active Filter Block Diagram

VII. MODELLING AND SIMULATION

In proposed system block diagram four major parts are concerned. Those are DFIG system, PV solar system, STATCOM system, and active filter.

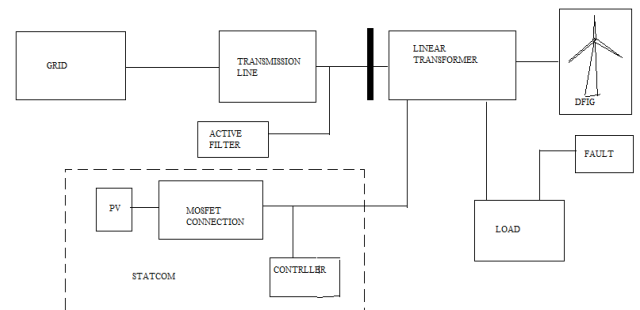

Fig.5 System block diagram

A. DFIG Modelling:

A very familiar model of induction generation converting the wind power to electricity and supply to the grid is shown in Fig 6. As shown the stator flux-oriented reference per frame, reactive power can be controlled by varying d -axis current of the rotor. Stator and rotor modified to a special reference frame which rotates with angular frequency and that is identical to stator flux linkage phasor graph with real axis and flux vector of stator. This is dynamic vectorized model [3].

The DFIG system generates 2 MW power and voltage across PCC is 230V. For wind power controller in this system PWM generator is used.

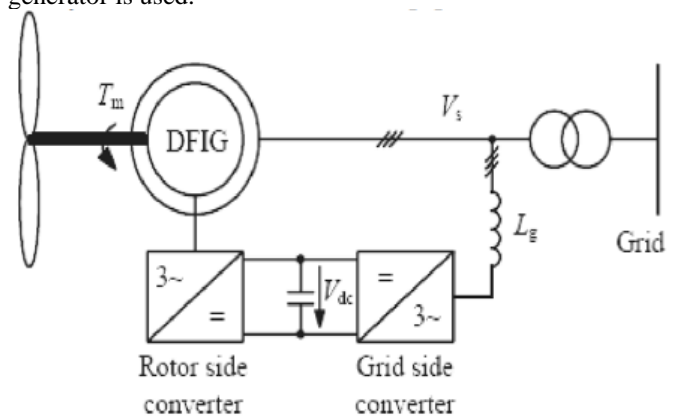

Fig.6 Wind Turbine DFIG

The main variable of the system is rotating are flux linkages

$$F_{qs} = W_b \int V_{qs} - \frac{W_r}{W_b F_{ds}} + r_s / x_{ls} (F_{mq} - F_{qs}) \quad (1)$$

$$F_{ds} = W_b \int V_{ds} - \frac{W_r}{W_b F_{qs}} + \frac{r_s}{x_{ls}} (F_{md} - F_{ds}) \quad (2)$$

$$F_{qr} = W_b \int \frac{r_r}{x_{lr}} (F_{mq} - F_{qr}) \quad (3)$$

$$F_{dr} = W_b \int \frac{r_r}{x_{lr}} (F_{md} - F_{dr}) \quad (4)$$

For maintaining the flow of variables and for convenience of simulating the above equations are separated to the rotor circuit and q-d axis.

The mechanical power and the stator electric power output are computed as follows:

$$P_r = T_m * \omega_r \quad (5)$$

$$P_s = T_{em} * \omega_s \quad (6)$$

For a loss less generator the mechanical equation is:

$$J \cdot \frac{d\omega_r}{dt} = T_m - T_{em} \quad (7)$$

In steady-state at fixed speed for a loss less generator

$$T_m = T_{em} \text{ and } P_m = P_r + P_s \quad (8)$$

and it follows that:

$$P_r = P_m - P_s = T_m \cdot \omega_r - T_{em} \cdot \omega_s = -s P_s \quad (9)$$

Where $s = \frac{\omega_s - \omega_r}{\omega_s}$ is defined as the slip of the generator.

$$P_w = C_p * (V_w) \quad (10)$$

Output torque is given by

$$T_m = P_t / V_{sh} \quad (11)$$

Where $P_t = P_m * (P_{wbase} * P_{nom}) / P_{ebase}$ and $P_{ebase} = (P_{nom} / 0.9)$

$$\lambda = (V_{sh} / V_w) * \lambda_{nom} \quad (12)$$

$$C_p = c_1 * [c_2 / \lambda - c_3 * \beta - c_4] * \exp(-c_5 / \lambda) + c_6 * \lambda \quad (13)$$

$$(1 / \lambda_i) = 1 / [\lambda + 0.08 * \beta] - 0.035 / [(\beta)^3 + 1] \quad (14)$$

$$C_{pnom} = C_{pmax} \quad (15)$$

$$\lambda_{inom} = 1 / (1 / \lambda_{nom} - 0.035) \quad (16)$$

$$k_{nom} = - (c_2 * c_5 / \lambda_{inom} - c_4 * c_5 - c_2) * \exp(-c_5 / \lambda_{inom}) / (\lambda_{nom}^2) \quad (17)$$

$$c_1 = C_{pmax} / ((c_2 / \lambda_{inom} - c_4) * \exp(-c_5 / \lambda_{inom}) + k_{nom} * \lambda_{nom}) \quad (18)$$

$$c_6 = k_{nom} * c_1 \quad (19)$$

By using the equation, we can simulate

a) Wind turbine 1/ lambda model (Tip speed ratio)

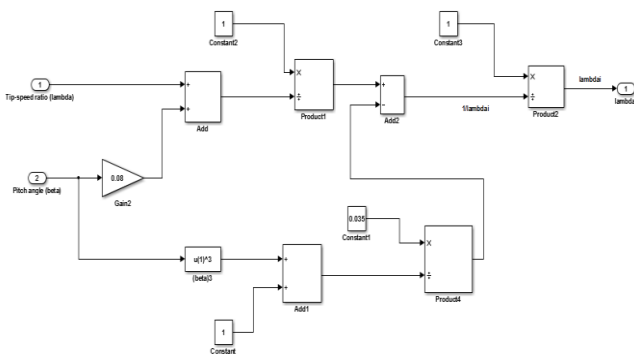

Fig.7 1/Lambda model

b) Pitch angle controller

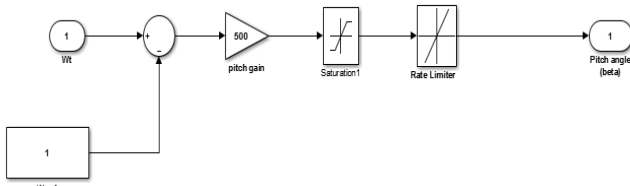

Fig.8 pitch angle controller

c) Wind turbine co-efficient of power model

By referring the above equations, we can simulate

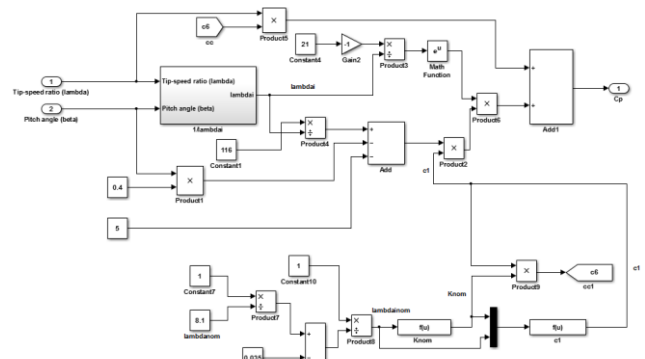

Fig.9 Cp Model

d) Wind turbine Modelling

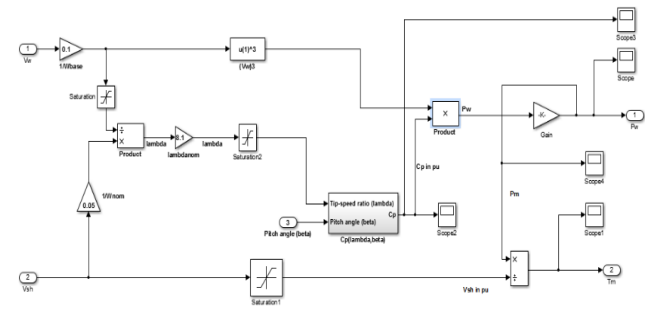

Fig.10 Wind turbine modelling

Drive Train Modelling

Drive train of a wind turbine mainly consists of turbine, generator and gear box. The main sources of inertia for the system lie in the turbine and generator and inertia of the gearbox is ignored owing to negligible contribution of tooth wheels. Thus, drive train is modeled as a two mass model with a connecting shaft inclusive of inertia and shaft elements [5].

The modelling of drive train as shown in figure 6.5 is carried out using the following mathematical equations [6]:

$$T_m - T_{sh} = 2 * H_t * (dW_t / dt) \quad (20)$$

$$(W_t - W_r) / W_{ebase} = [d(\theta_{sta}) / dt] \quad (21)$$

$$T_{sh} = [\theta_{sta} * K_{ss} + K_d * (W_t - W_r)] \quad (22)$$

$$T_{base} = P_{nom} / W_{ebase} \quad (23)$$

$$T_m = T_{base} * T_{sh}$$

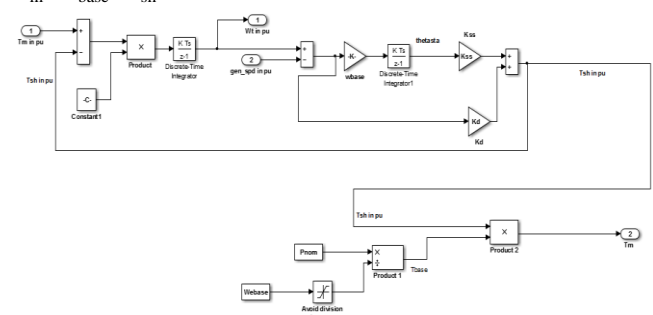

Fig.11 Drive train modelling

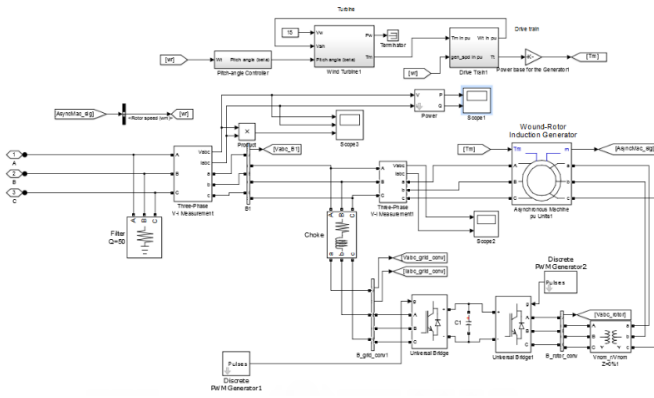

Fig.12 DFIG model

B. PV Solar System Modelling:

By connecting the PV cell series and parallel it is possible to get desire output with PV cell, In this PV Solar system all fundamentals to generating current, saturation current, reverse current considered. And the system shown below, The PV solar system generates 230V for hybrid system and 40 Volts as required to STATCOM.

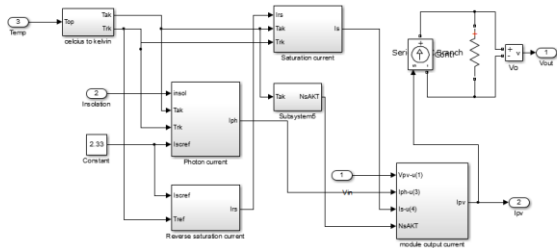

Fig.13 PV solar system

C. SOLAR POWER STATCOM AND AF

In this model solar power STATCOM is used. Existing PV solar system used as a source of the STATCOM. Active filter is used to mitigate voltage distortion. It's a great idea to use non-conventional power system to regulate the grid. The STATCOM PI controller is shown in Fig.14,

Active filter equations based on transfer function,

$$A(S) = \frac{1 + R_2}{1 + W_c R_1 C_1 s} \dots(i)$$

And resistance equations,

$$R_i = \frac{A_i}{2\pi f_c C_i} \dots(ii)$$

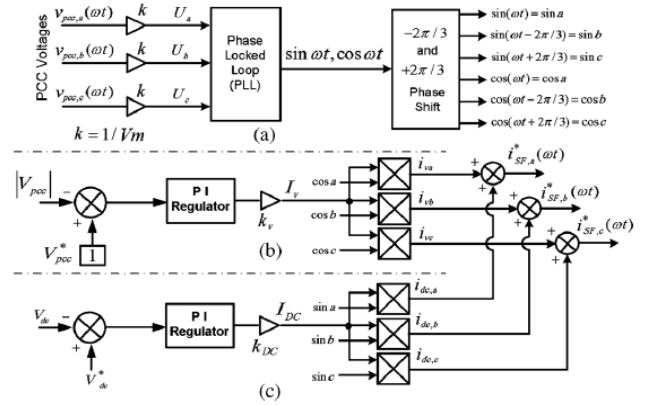

Fig.14 STATCOM controller

In this system 3 phase fault is created to preparing voltage sag, and it is connected to the transmission line to grid for generating more distortion. An Active Filter is used to mitigate the transmission line distortion and system reliability.

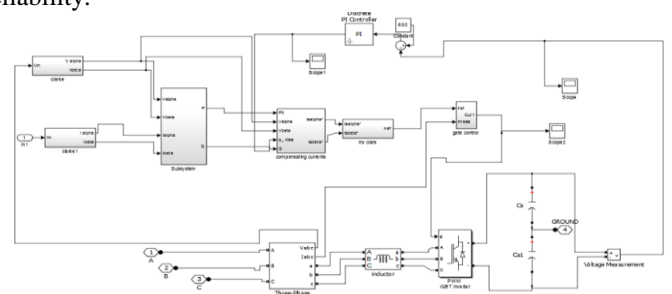

Fig.15 AF simulation model

The system simulation diagram is shown below.

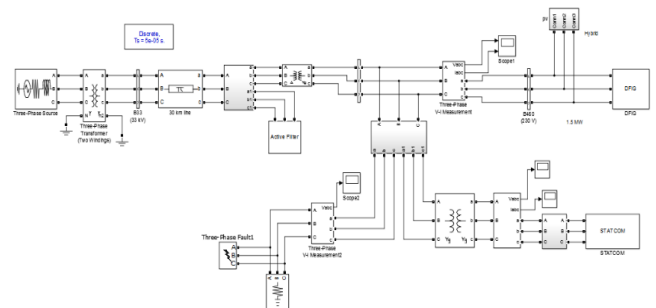

Fig.16 DFIG and STATCOM connected to grid

VIII. SIMULATION RESULTS

As taking PV solar system the source of STATCOM in continuous 40 DC volt. The PV output is shown in Fig.16

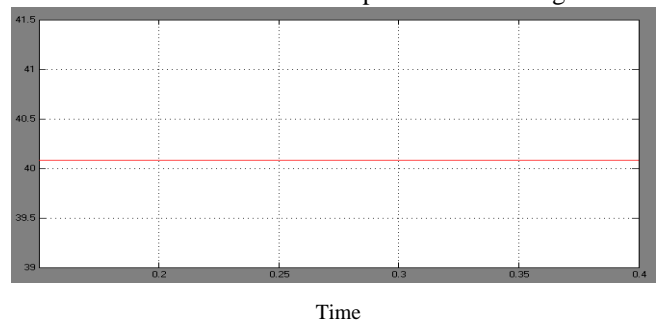
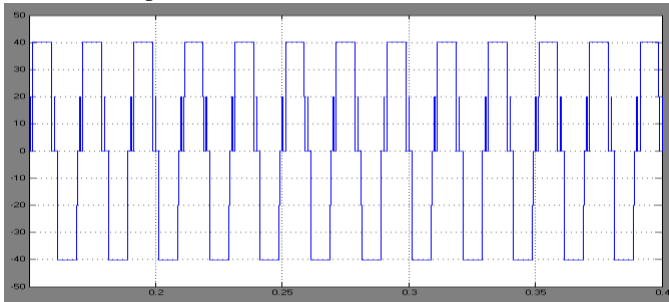

Fig.17 PV output as source of STATCOM

As STATCOM supplied by 40V DC, the three level STATCOM output is also 40V is shown below.



Voltage vs Time

Fig.18 STATCOM output

By designing the DFIG for 2 MW of power and 230V to PCC, it is very complex and challenging. The wind power depends each and every factor mentioned. Here at time 0.03 to 0.05 the current of DFIG distorted because generators rotor side characteristics.

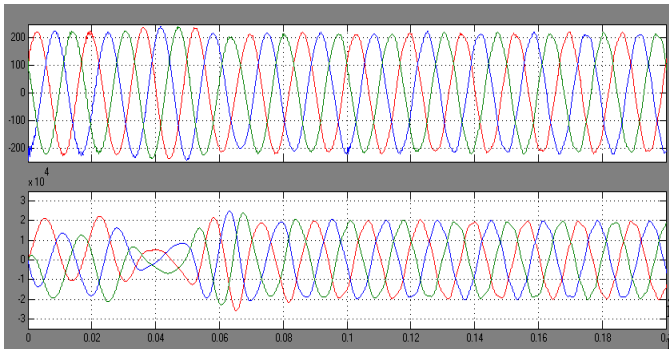

Voltage and current vs Time

Fig.19 Voltage and current of DFIG

The active and reactive power of the DFIG system is shown below where active power is 2 MW.

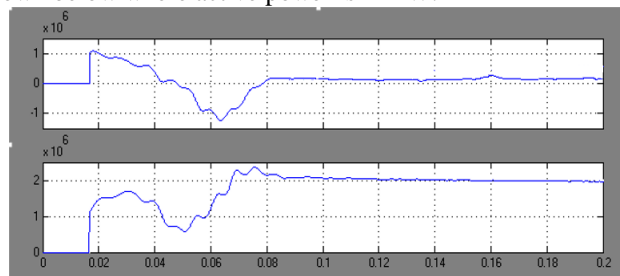
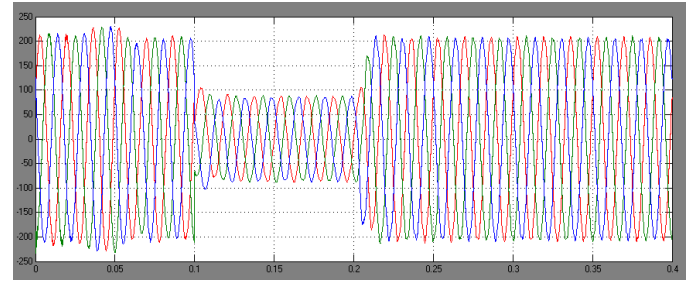

Fig.20 Reactive and a=Active power of DFIG

For first case without STATCOM fault is given across the load of the existing system with the fault time of 0.1 to 0.2 and fault type is three phase fault with load of 500 KW. PCC voltage is 230V. Grid generation 100 MW. WES is 2 MW.

At time t=0 the voltage is normal 230V, and system is reliable. At time t=0.1 three phase fault occurs and system drops to the voltage sag zone, 60 percent voltage drop occurs up to t= 0.2. At t=0.2 to 0.4 the fault clears and the system return to its normal state.



Voltage vs Time

Fig.21 Voltage sag in the system

In second case when STATCOM is connected to the system, so when voltage sag occurs at t=0.1 sec the STATCOM injects the voltage to the system to mitigate the sag up to t=0.2

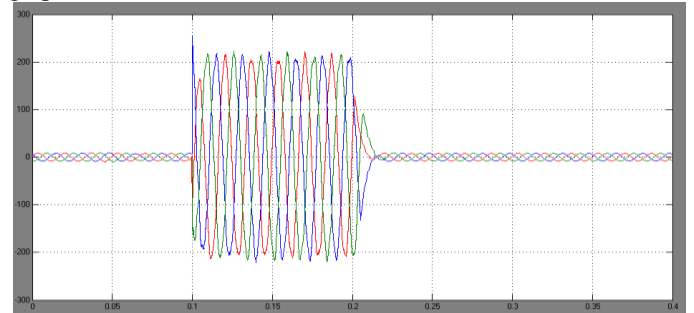
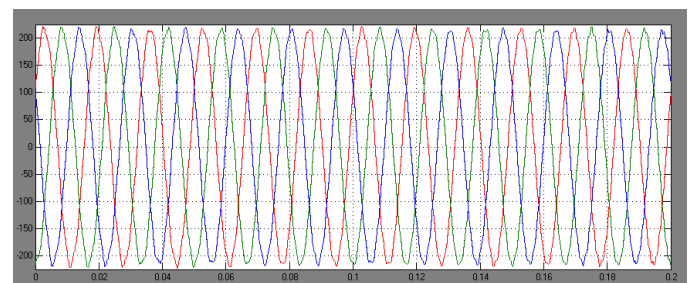

Fig.22 STATCOM injection voltage

After mitigation the system voltage sag, the voltage graph is shown below. STATCOM not only mitigate the sag but also mitigate very small distortion exist in the system.



Voltage vs time

Fig.23 Final system voltage after connecting STATCOM

Voltage output as require 230V without any distortion in the PCC to transmission line a Time ided by the system.

The system used Frequ ominal transformer power = 1000MVA. Transformer ratio = 25000/230. Wind power generation = 2 MW. $\lambda_{nom}=8.1$. $C_{pnom}=0.48$.

IX. CONCLUSION

A PV solar power STATCOM and AF with DFIG wind power and solar based hybrid system is studied in this paper. Where the STATCOM mitigates the voltage sag of the system during fault and wind and solar power system supply 2MW power to the grid. As the solar system is connected only in STATCOM as source, and AF is used to mitigate distortion of the system but it has the main role of the system that is

regulate the grid voltage in any situation. This concept shows that without any extra power requires the non-conventional energy resources regulates the grid voltages. This concept allows to use more non-conventional resources not only as DG types but also different way like source of voltage regulator devices for better performance.

A novel concept can be proposed by using battery with PV as STATCOM source for day and night usage, cause PV practically does not generates the power. But it is possible to charge the battery by PV in day time and regulate the grid using PV and Battery power STATCOM to regulate the grid voltage during day and night time. Using the STATCOM and AF together is also a great challenge but it is heavily effective to mitigate power quality problems of the system.

ACKNOWLEDGMENT

I would like to express my gratitude to the Management of SRM University for providing the infrastructure and facilities for doing the research work.

I express my sincere thanks and profound gratitude to my Project Guide, Ms.R.Ramya, M.Tech, Assistant Professor who has been a constant source of inspiration and support for guiding the course of the project work. It has been an excellent experience working with her which I can never forget.

And also my thanks to the entire EEE department faculty and supporting staff for their good support for completing my present project in successful manner.

Last but not the least, I thank my cheerful Parents & Friends who chipped in with timely advices, constant appreciation and criticism and also for giving a great company all along.

REFERENCES

- [1] Rajiv K.Varma, Vinod Khadkikar, and Ravi Seethapathy, "Night time Application of PV Solar Farm as STATCOM to Regulate Grid Voltage", IEEE Transaction ON Energy Conversion, VOL. 24, NO.4, pp.983-985, Dec 2009.
- [2] Rajiv K. Varma, Vinod Khadkikar, and Ravi Seethapathy, "Grid Voltage Regulation Utilizing Storage Batteries in PV Solar – Wind Plant based Distributed Generation System", IEEE Electrical Power & Energy Conference, Oct 2009.
- [3] B.Chitti Babu , K.B.Mohanty," Doubly-Fed Induction Generator for Variable Speed Wind Energy Conversion Systems- Modelling & Simulation," International Journal of Computer and Electrical Engineering, Vol. 2, No. 1, pp.141-147 February, 2010
- [4] Amiraser Yazdani Prajna Paramita Dash, " A Control Methodology and Characterization of Dynamics for a Photovoltaic (PV) System Interfaced With a Distribution Network," IEEE Transactions on power delivery, VOL. 24, NO. 3, pp. 1538-1551 Jul 2009.
- [5] D.Johnson and J.Hilburn, "Rapid Practical Designs of Active Filters, John Wiley & Sons" oxford press, June 2013.
- [6] Min Min Kyaw, V.K. Ramachandaramurthy, "Fault ride through and voltage regulation for grid connected wind turbine", Renewable Energy 36 (2011) 206e215, March 2010.
- [7] Rajiv K. Varma, Vinod Khadkikar, and Ravi Seethapathy, " Grid Voltage Regulation Utilizing Storage Batteries in PV Solar –

- Wind Plant based Distributed Generation System", IEEE Electrical Power & Energy Conference, Oct 2009.
- [8] B. Singh, S.N. Singh and L. Wang, Electric grid connection and system operational aspect of wind power generation, in Wind Energy Conversion System: Technology and Trends, S.M. Muyeen, (Eds.), Springer-Verlag: UK 2012



Firoz Sarkar, completed B.Tech in EE from MCET in 2013 and M.tech in Power Systems from SRM University in 2015. Research on "Design a Solar Power STATCOM to Mitigate the Voltage Sag in a Grid Connected Wind Energy System" published in Springer. Currently working on hybrid power system.