

# Design of a low cost embedded system to prevent vehicle theft based on GSM by using AVR

Chanchal Raj, Santosh Mohan Rajkumar

**Abstract**— Now-a-days, increasing no. of incidents of vehicle theft have become a major problem in society. To prevent vehicle theft we can install an embedded system in the vehicle which takes care of this thing. In this paper, we deal with design of an embedded system to prevent vehicle theft. The proposed system makes use of AVR (Advanced Virtual RISC) microcontroller interfaced with a GSM module. After installing the system in the vehicle, if the vehicle is being stolen then the owner can control the ignition, say it to lock the vehicle or stop the engine by communicating with the GSM module from a mobile phone. The owner can bring back the vehicle to normal condition after entering a secured password. Tracking of the vehicle is also possible due to the presence of SIM card in the GSM module. The system is designed in a single chip & the cost is very less.

**Index Terms**—Vehicle tracker, GSM, AVR .

## I. INTRODUCTION

In recent years, vehicle thefts are increasing at an alarming rate around the world. According to National Crime Information Center (NCIC), in 2006, 1,192,809 motor vehicles were reported stolen, the losses were 7.9\$ billion [1]. People have started to use the theft preventing systems installed in their vehicles. The commercially available anti-theft vehicular systems are very expensive. Therefore in this paper we propose a simple low cost embedded system to serve this purpose. The embedded system block consist of an AVR microcontroller, GSM module, LCD, keypad, relay circuitry, power supply unit.

GSM (Global System for Mobile Communications, originally Groupe Spécial Mobile), is a standard developed by the European Telecommunications Standards Institute (ETSI) to describe the protocols for second-generation (2G) digital cellular networks used by mobile phones, first deployed in Finland in July 1991. As of 2014 it has become the default global standard for mobile communications - with over 90% market share, operating in over 219 countries and territories. The network structure of GSM is divided into a number of discrete sections as follows [7]:

- Base Station Subsystems (the base stations & their controllers)
- Network and Switching Subsystem (the part of the network most similar to a fixed network, sometimes just called the "core network").
- GPRS Core Network (the optional part which allows

packet-based Internet connections).

- Operations support system (OSS) (network maintenance).

## II. THE DESIGNED EMBEDDED SYSTEM

The block diagram of the proposed embedded system is shown in Fig 1. The power supply unit draws power from car's battery & supplies 5V to AVR microcontroller & 12V to relay connected to ignition & fuel supply system of the car. When the vehicle is stolen, the owner can send an SMS typing "STOP" followed by a password from his mobile phone to the secret mobile number of the GSM module. Microcontroller takes SMS signal from the GSM module, reads the instruction it & compares the password with the value set by the owner. If the password matches then the microcontroller disconnects relay from the circuit & the vehicle will stop. The vehicle can be brought back to normal position in two ways: either the owner can send a message typing "RESET" followed by the password or by directly entering the password through the keyboard on spot. The LCD is there to show relevant information. The owner can anytime change the password by using the keyboard after providing the current password.

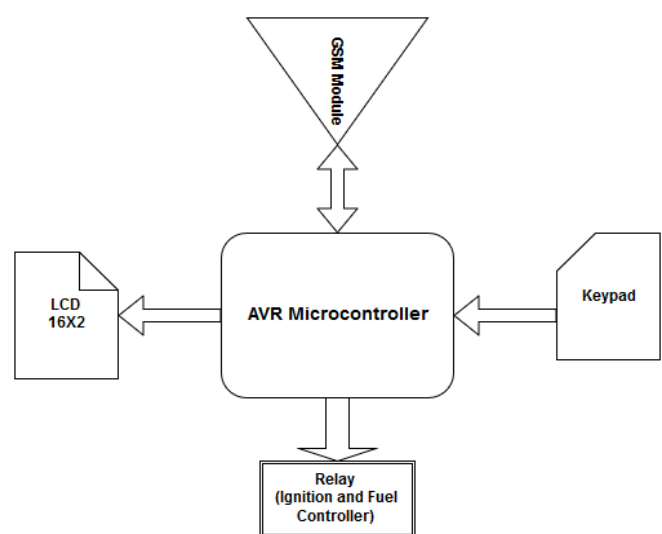

Figure 1: Block Diagram of the embedded system.

### A. AVR Microcontroller

The heart of the system lies in the AVR microcontroller, which handles all signals. It is an 8-bit microcontroller which works on 16 MHz crystal frequency. The version of AVR we are using here is ATmega32 by atmel. The key features of ATmega32 are:

- High-performance, Low-power consumption.
- Advanced RISC architecture.
- High endurance non-volatile memory segments.
- JTAG (IEEE std. 1149.1 Compliant) interface.

The pin configuration of ATmega32 is shown below in Fig. 2.

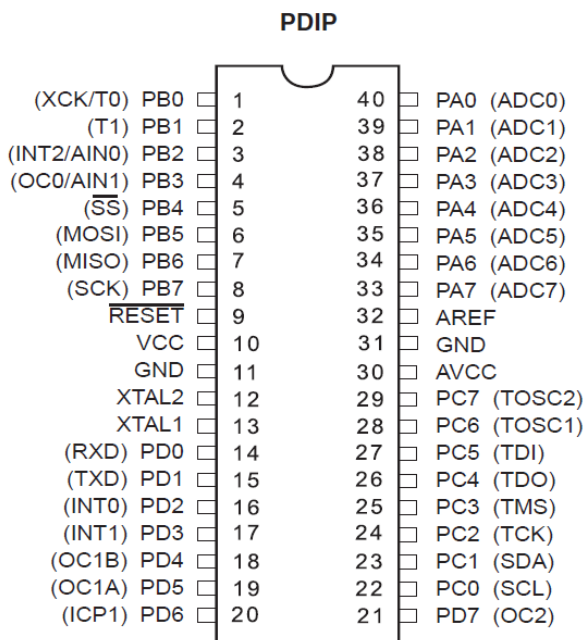

Figure 2: Pin configuration of ATmega32 (DIP)

### B. Keypad

The keypad that has been used here is in the form of (4 x 4) matrix form to give input data (i.e. password, during validation process). The keypad is connected with AVR microcontroller row-wise from PB4 to PB7 & column-wise from PB0 to PB3. The rows are connected to an output port and the columns are connected to an input port. If no key has been pressed, reading the input port will yield 1's for all columns since they are all connected to high (Vcc). If all the rows are grounded and a key is pressed, one of the columns will have 0 since the key pressed provides the path to ground. It is the function of the microcontroller to scan the keyboard continuously to detect and identify the key pressed. The circuit diagram of the designed keyboard is shown in Fig. 3.

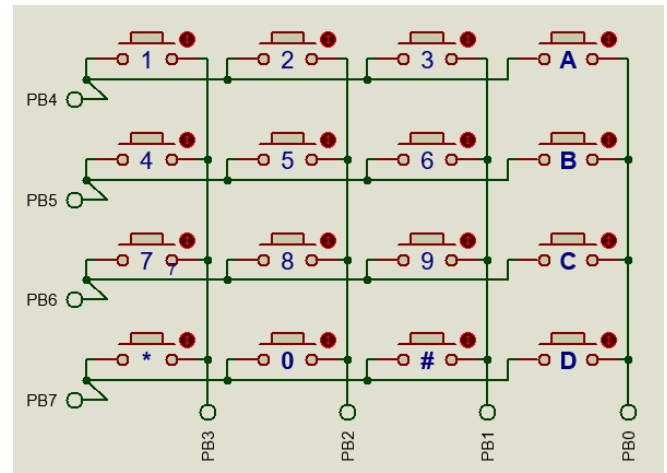

Figure 3: The designed keypad

### C. LCD

The LCD is used to display messages. The data ports of LCD are connected from PA0 to PA7 of microcontroller & control pins RS, RW, E are connected to PC0, PC1, PC2 of microcontroller respectively. A variable resistor RV1 is connected to VEE port of LCD which is used to adjust contrast of LCD. The LCD used here is LM016L which is capable of displaying alpha numerics in 16 x 2 dot matrix.

### D. Relay

The relay we are using here is driven by Power MOSFET (IRF830) and we apply the output of AVR microcontroller to the gate of MOSFET. The MOSFET is biased by 12V supply from the battery. The relay completes the ignition circuit & also the circuit of a choke coil in the fuel injection system of the vehicle. Whenever the relay changes its state it disconnects the ignition circuit & the choke coil will come into action discontinuing the fuel supply to engine. Thus vehicle stops. The vehicle comes into normal position when microcontroller brings back the relay to the original state.

### E. The GSM Module

We are using SIM900A GSM module with GSM/GPRS which works on frequency 900/1800 MHz. The receiver (Rx) pin of GSM module is connected to Tx (pin 15) of microcontroller & transmit (Tx) pin of GSM module is connected to Rx (pin 14) of microcontroller. The default baud rate of both module & microcontroller is 9600. The GSM module communicates with the microcontroller serially as per UART (Universal Asynchronous Receive Transmit) protocol. The signal of module contains Data Bits: 8, Parity: none, Stop Bit: 1. The frequency & baud rate can be modified using AT command.

III. SCHEMATIC HARDWARE DESIGN

The schematic hardware simulation circuit for the embedded system to prevent vehicle theft is shown in Figure 4. In this simulation circuit we are showing two lamps showing the state of ignition and choke coil connected to NC & NO state pins of relay respectively.

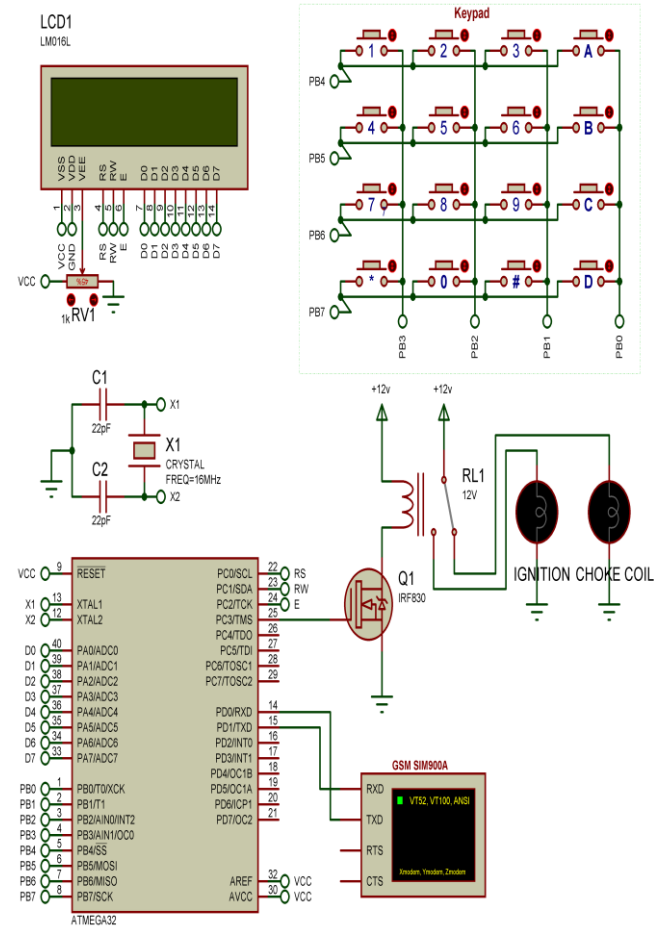

Figure 4: Simulation Schematic of the embedded system.

Whenever the microcontroller changes the state of the relay upon getting SMS having “STOP” instruction along with the correct password, the ignition circuits gets opened & choke coil circuit gets closed which ultimately stops the vehicle. The owner can anytime bring back the vehicle into normal condition as stated earlier.

The working of choke coil in fuel injection system, with solenoid valve which controls the flow of fuel as depicted in Figure 5 below.

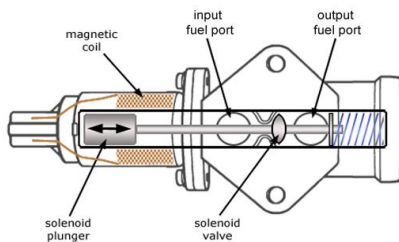

Figure 5: Choke coil in fuel injection system

IV. CONCLUSION

With the designed embedded system installed in vehicle, vehicle theft can be prevented, also with SIM tracking feature location can be found out. The system components are very much cheap & hence the cost of the system is very less. The implementation of the system is very simple & hence vehicle owners can easily avail the benefit of it.

REFERENCES

- [1] M. Ramadan, M. Al-Khedher, and S. Al-Kheder, “Intelligent anti-theft and tracking system for automobiles,” Int. J. Mach. Learn. Comput., vol. 2, no. 1, pp. 83–88, Feb. 2012.
- [2] Asaad M. J. Al-Hindawi, Ibraheem Talib, “Experimentally Evaluation of GPS/GSM Based System Design”, Journal of Electronic Systems Volume 2 Number 2 June 2012.
- [3] Zhai Guorui, and Dai Shenghua. Design of auto guard against theft system based on GPRS and GPS[J]. Microcontrollers and Embedded Systems, Bei Jing, 2007, 8: 39-41.
- [4] Xavier Lagrange, Philippe Godlewski, Sami Tabbane. GSM network and GPRS[M]. Beijing: Electronic Industry Press. 2002.
- [5] Pravada P. Wankhade and Prof. S.O. Dahad , “Real Time Vehicle Locking and Tracking System using GSM and GPS Technology-An Anti-theft System”, International Journal of Technology And Engineering System, vol. 2, no.3, Jan –March 2011.
- [6] Sehgal, V.K.; Singhal, M. ; Mangla, B. ; Singh, S. ; Kulshrestha, S. “An Embedded Interface for GSM Based Car Security System”, IEEE Conference, 2012 Fourth International Conference on , Computational Intelligence, Communication Systems and Networks (CICSyN), pages 9-13, July 2012, DOI: 10.1109/CICSyN.2012.12.
- [7] en.wikipedia.org .

**Chanchal Raj** is presently pursuing his B.Tech degree in Electronics & Communication Engineering at National Institute of Technology, Silchar, India.

**Santosh Mohan Rajkumar** is presently pursuing his B.Tech degree in Electrical Engineering at National Institute of Technology, Silchar, India.