

# LIFETIME IMPROVEMENT OF WIRELESS SENSOR NETWORK USING NETWORK CODING AND ADAPTIVE DUTY CYCLE

Tripti Sharma<sup>1</sup>, A.N Mishra<sup>2</sup>, Arun Kumar Yadav<sup>3</sup>

<sup>1</sup>M-Tech Degree in Electronics and Communication, UPTU Lucknow

<sup>2</sup>Associate Professor & Head of Department of Electronics & Communication, Krishna Engineering College, Ghaziabad

<sup>3</sup>Design Engineer, Sapro Robotics, Ghaziabad

## Abstract

Wireless sensor networks (WSNs) are composed of very low cost, low power consuming devices with sensing, signal processing and wireless communication systems. Minimizing energy consumption and maximizing network lifetime are important issues in the design of protocols for sensor networks.

Wireless sensor network consists of automatic sensors, which have a limited power battery. Nodes that are present near the centralized collecting point will be in demand of much power which limits the overall network life time. The active area near to the sink node creates a bottleneck zone because of the presence of large traffic-flow which causes minimization of the network lifetime in wireless sensor network. In this project, we introduce an adaptive duty cycle and encoding technique for energy consumption minimization in the bottleneck zone. An efficient technique of communication has been adopted in the bottleneck zone by using the combination of adaptive duty cycle and encoding technique. Energy efficiency of the bottleneck zone will get increased due to more volume of the data that would be transmitted to the sink with the same number of transmissions. Hence the lifetime of the wireless sensor network is increased. This work archive to the enhancement of the energy efficiency of the bottleneck zone which in turn leads to overall improvement of the network lifetime by considering an network coded adaptive duty cycle WSN. Linear Network coding does not simply relay on the packets of information that they receive, the sensor nodes of a network take several packets and combine all of them together for the transmission and apply it to the bottleneck zone. By applying the above techniques we finally achieve the increased overall lifetime of node. This proposed system investigates life time improvement approx 8% - 14%, and minimizing energy consumption.

**Keyword:** WSN, Duty Cycle, Network Coding, Network Lifetime, Upper Bound.

## I. INTRODUCTION

The vast advancements in technology in general and in wireless communications have specifically give us the capability to mass-produce small, low-cost sensors that can connect to each other wirelessly. The sensors once deployed, whether in a random or a pre-engineered way will connect to each other in system and form a wireless sensor network (WSN), which are made of a large number of sensors deployed in a predefined area. The sensors would transform physical data into a form that would make it easier for the user to understand. WSN technology is growing rapidly, becoming cheaper and easier to afford, and allowing different kinds of application usage of such networks. WSNs can be used for a wide variety of applications dealing with monitoring (health environments, seismic, etc.), control (object detection and tracking), and surveillance (battlefield surveillance) [6, 7, 4, 5].

Wireless Sensor Networks consists of number of sensor nodes that are used in the deployment for monitoring the areas such as deserts, Forest fires, glaciers etc including industrial monitoring system and military applications each sensor nodes consists of a microcontroller, microprocessor, ARM processor, Radio frequency transceivers using which they process the data. Xbee protocol can be used as RF based communication. In each sensor node battery energy is limited for which enhancement of energy consumption becomes major challenge. The ratio between active mode and sleep mode is called duty cycle they save energy between active and sleep mode. In this WSN adaptive duty cycled method has been adopted, these sensor nodes turned on and off in a mannered fashion. The network coding technique which provides better utilization of bandwidth and also encodes the incoming data packets and then transmits the encoded packet towards the sink node the network coder nodes uses single hop for communication and other types of sensor nodes use multihop communication.

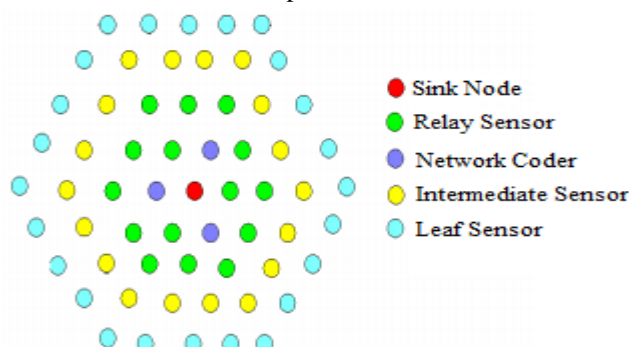

Fig. 1 Roles of Sensor in typical WSN

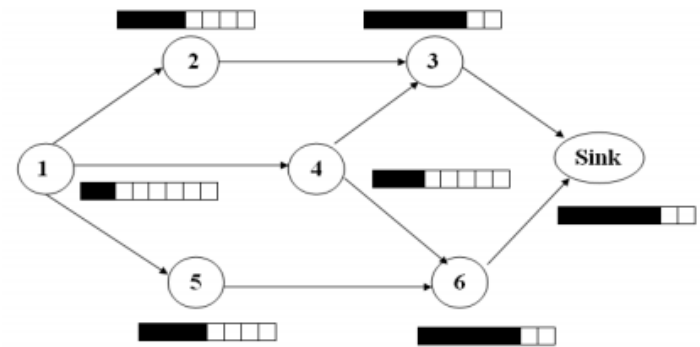

Fig. 2 Adaptive Duty Cycle in a typical WSN

A duty cycle WSN could be categorized into three main types: random duty-cycled WSN [1], co-ordinated duty-cycled WSN [2], Adaptive duty-cycle WSN [3], in the first type that is the random duty-cycle the sensor nodes can be turned on or off state independently in a random manner. Also the random duty-cycle WSNs are one of the simple type to design as there will be no additional overhead is required, however the disadvantage of a random duty cycled WSN is that that it will not go to the sleep state based on their network condition. It will cause heavy traffic generation. So it will not use utilizes the bandwidth efficiently. In the second one that is the coordinated duty cycle the sensor node communicates among themselves using the communication and message exchange. However, that needs an additional information exchange in order to broadcast the active sleep schedules of each node. This will cause the heavy traffic generation and overhead. We propose an adaptive duty cycle control mechanism which is based on the queue management that aims of power saving and delay reduction. The proposed scheme does not require any explicit state information from the neighbouring nodes, but only utilizes the available possessive queue length at the node. The network condition or traffic variations causes some change in implicitly because the queue states having possibility or power of the network states. By using the queue length and its variations of a sensor node, we presents a design of distributed duty cycle network controller. Therefore the design of WSN based on adaptive duty has been considered. Specifically traffic reduction problem in the bottleneck zone has been considered.

## II. RELATED WORK

Energy consumption reduction in a denser WSN has been facilitates by using duty cycle. Adaptive duty cycle with network coding technique has been drawn its attention for improvement of sensor network lifetime and energy efficiency in resource constraint wireless networks.

Several studies regarding the network lifetime in WSNs has been done till date. The network lifetime upper bounds has been derived in [10][11][9]. Upper bounds on network lifetime for a non-duty cycle based WSN has been derived by Bhardwaj *et al.* [11] and Wang *et al.* [9]. Lee *et al.* [10] estimates the network lifetime upper bounds in a cluster based WSN. Zhang *et al.* [12] derived a network lifetime for a non-duty cycle based WSN. Karkvandi *et al.* [13] proposes a lifetime-awared routing scheme.

Several works has been done and literated on broadcasting, connectivity and coverage in the field of duty cycle based WSNs. Wang *et al.* [14] gives the duty cycle based broadcasting scheme with proper reliability. However, a recent work proposed by Gu *et al.* [15] which considers duty cycle with respect to communication in an energy harvesting WSN.

Hsin *et al.* [21] proposes a random duty cycle based WSN has been used for dynamic coverage. Futhermore, an efficient broadcasting scheme in duty cycled WSNs have also proposed by Lai *et al.* [16]. Kim *et al.* [17] studies the coverage and connectivity of low duty cycled WSN.

Ahlsweide *et al.* [20] introduces the information theoretic aspect of network coding for information networks. Lun *et al.* [18] proposes a random linear network coding based scheme which provides packet-level capacity for both single unicast and single multicast connections for wireless networks. A network coding based probabilistic routing scheme that gives gains of network coding in a WSN has been presented by Rout *et al.* [19].

### III. ENERGY CONSUMPTION MODEL

A sensor node consumes energy at different states, such as, like sensing and generating data, transmitting, receiving and sleeping state. In this work, the radio model [22] has been modified for a duty cycle based WSN. Energy savings has been done at the node level by switching between the active and the sleep states.

Energy consumption by the source node per second across a distance  $d$  which have path loss exponent  $n$  is,

$$E_{tx} = R_d(\alpha_{11} + \alpha_2 d^n)$$

Where  $R_d$  is the data rate of transceiver relay,  $\alpha_{11}$  is the per bit energy consumption by the transmitter and  $\alpha_2$  is the per bit energy consumption in the transmit op-amp [22]. Total energy consumption in time  $t$  by the source node (leaf node) without acting as a relay (intermediate node) is,

$$E_s = t[p(r_s e_s + E_{tx}) + (1 - p)E_{sleep}]$$

where  $E_{sleep}$  is the idle mode energy consumption of the sensor node per second,  $r_s$  is the sensor's average sensing rate and is also equal for all the nodes,  $e_s$  is the energy consumption of a node to sense a bit, the probability  $p$  is the average proportion of time  $t$  that the sensor node use in active mode. Thus,  $p$  is the duty-cycle. A sensor node remains in the idle state till time  $t$  with probability  $(1-p)$ . The per second energy consumption by an intermediate node that act as a relay mote is given by

$$E_{txr} = R_d(\alpha_{11} + \alpha_2 d^n + \alpha_{12})$$

Where  $\alpha_{12}$  is that energy which is consumption by the sensor node in order to receive a bit. Total energy which is consumed till time  $t$  by an intermediate (relay) node is

$$E_r = t[p(r_s e_s + E_{txr}) + (1 - p)E_{sleep}]$$

### IV- ADAPTIVE DUTY CYCLE

A system  $N$  sensor nodes scattered uniformly in the area  $A$  is considered. All the  $N$  sensor nodes are Adaptive Duty Cycle Enabled (switching between active and dormant state based on their Queue value) in the zone  $B$ , the nodes are differentiating into two groups such as relay sensor and Linear Network Coder Sensor nodes. The data has been transmitted by the active relay sensor nodes( $R$ ) which are generates outside as well as inside in the bottleneck zone. The relay nodes can communicate to the sink using a single hop communication, the relay node communicate to the another relay node and Liner network coder node using a multi hop communication in the bottleneck zone . The active Linear Network Coder sensor nodes encode the relay node data before transmitting it to the sink. It uses the single hop for communicate with the sink. The leaf sensor nodes will periodically sense the data and transmit all of them to the neighbouring nodes towards the sink. The intermediate sensor nodes periodically senses the data and further it will relay the sensed data and received data in the direction of sink  $S$ . Each sensor node that has got a number of Received queue and sensed Queue which are attached to it, one or more to other nodes, more to the sink. Except the Leaf (or) Terminal node and Sink node the packets are arrived and depart on each sensor node. The proposed approach is to dedicate the buffer at each node to a single FIFO queue. The switch begins to the sensor node as an active state as the buffer occupancy exceeds a threshold until buffer occupancy falls below the threshold level again. The sensor node would go to the dormant (sleep) state if the buffer size below the threshold.

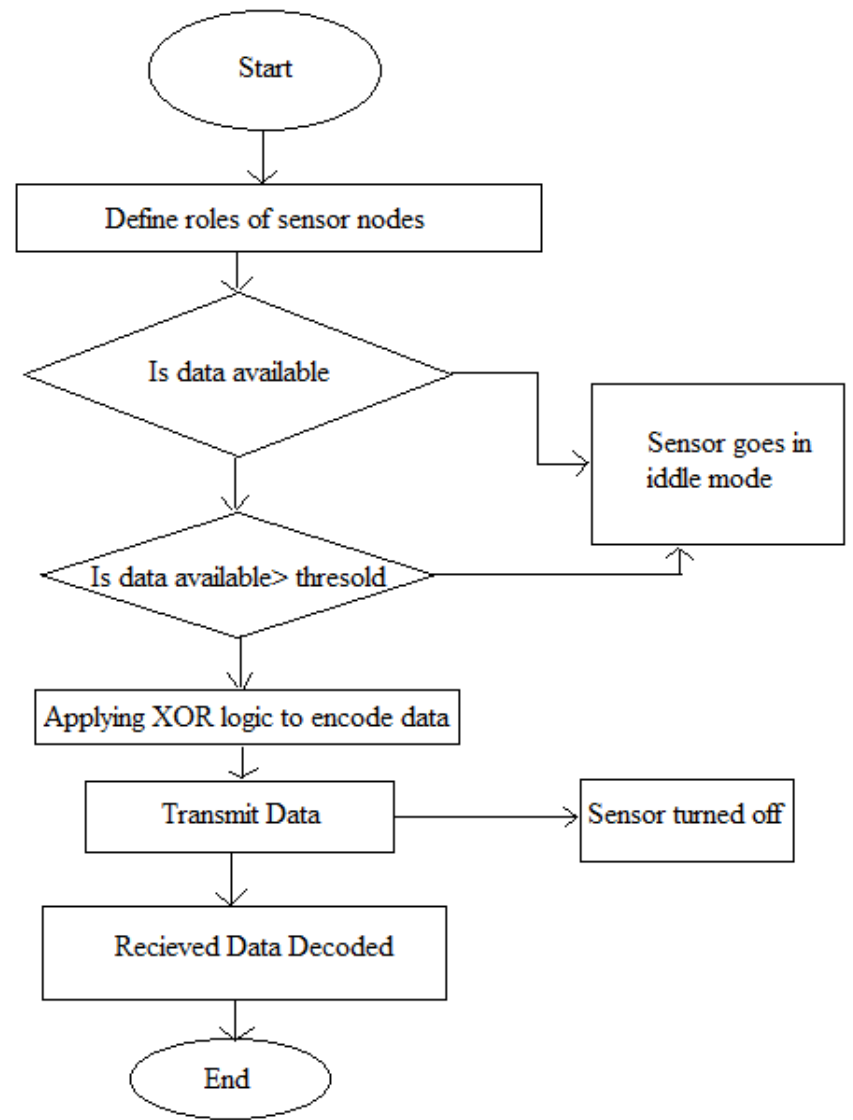

Fig. 3 Flow chart of project

### V- SIMULATION & RESULTS

#### 1 Network Lifetime using Random Duty Cycle

In this project area of wireless sensor network is considered 200x200 square meter, diameter of bottleneck zone 60m, number of nodes 1000, battery energy 25kj, sleep energy 30uj, hop length 2, number of bits 960 and threshold 12 bit are considered.

Fig 4 shows wireless sensor network lifetime variation with respect to change in random duty cycle. When duty cycle value is 0.01lifetime for  $m=1$  is  $8.26 \times 10^8$  seconds. As value of duty cycle increases lifetime decreases, and with the increase in value of  $m$  (traffic density) lifetime decreases.

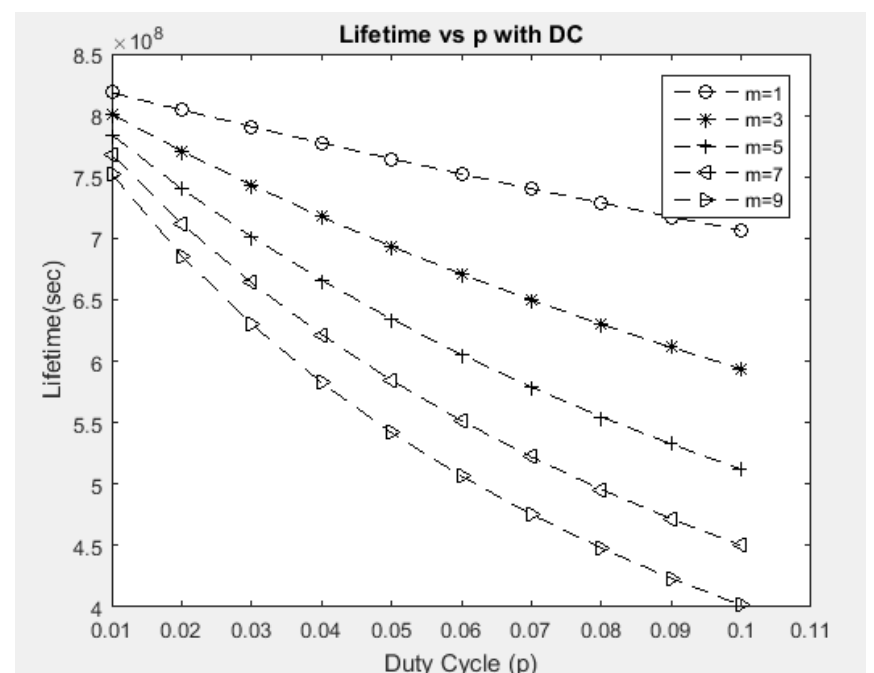

Fig. 4 Lifetime of Sensor Network using Random Duty Cycle

## 2 Network Lifetime using Network Coded Random Duty Cycle

Fig 5 shows wireless sensor network lifetime variation with respect to change in random duty cycle. When duty cycle value is 0.01, lifetime for  $m=1$  is  $8.32 \times 10^8$  seconds. As value of duty cycle increases lifetime decreases, and with the increase in value of  $m$  (traffic density) lifetime decreases.

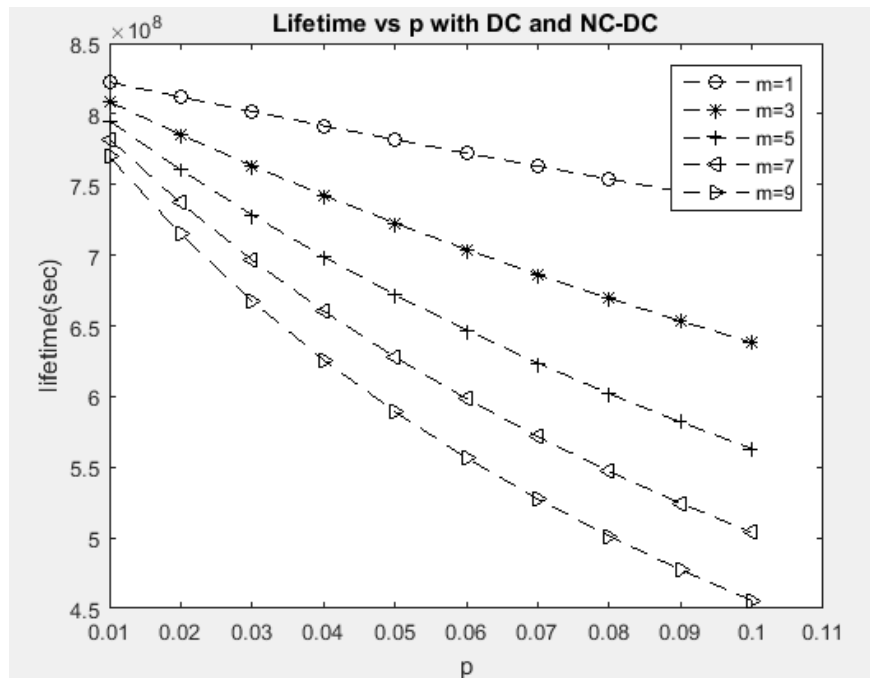

Fig. 5 Lifetime of Sensor Network using Random Duty Cycle

## 3 Network Lifetime using Network Coded Adaptive Duty Cycle

Fig 5 shows wireless sensor network lifetime variation with respect to change in random duty cycle. When duty cycle value is 0.01, lifetime for  $m=1$  is  $8.38 \times 10^8$  seconds. As value of duty cycle increases lifetime decreases, and with the increase in value of  $m$  (traffic density) lifetime decreases. For  $m=9$  and  $p=0.01$  lifetime is  $7.8 \times 10^8$  seconds.

Table 1: Parameters

Number of Nodes (N)	1000
Area (A)	200 m <sup>2</sup>
Path Loss Exponent	2
Alpha11	0.937uj
Alpha12	0.787uj
Alpha2	0.0172uj
Sleep	30uj

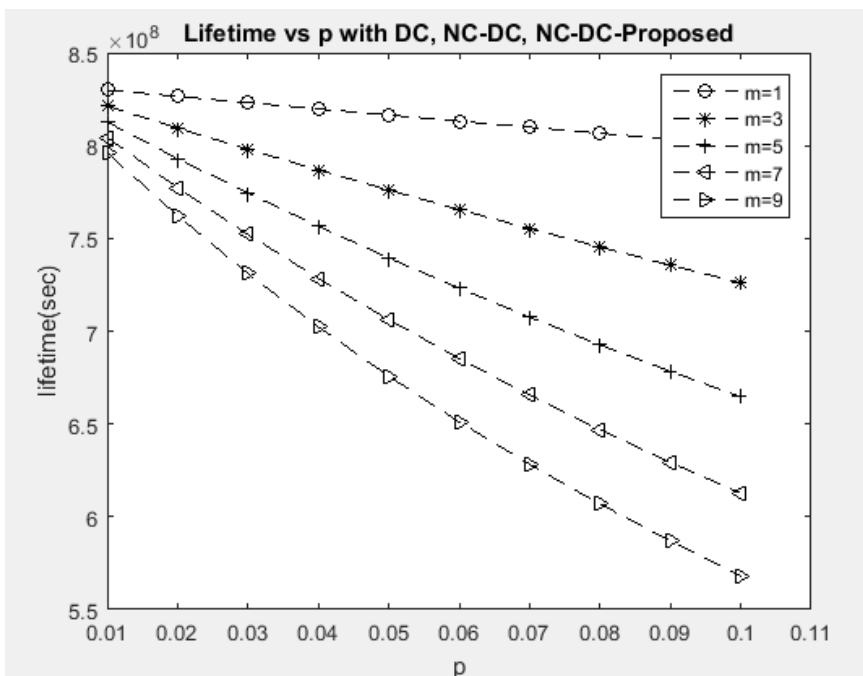

Fig. 5 Lifetime of Sensor Network using Adaptive Duty Cycle and Network Coding

## CONCLUSION

In a wireless sensor network (WSN), the area around the *Sink* creates a bottleneck zone that has maximum traffic flow. Hence, the WSN network lifetime is dictated by the lifetime of the bottleneck zone. The network lifetime of upper bounds have been estimated with (i) adaptive duty cycle, (ii) network coding and (iii) combinations of adaptive duty cycle and network coding. It has been observed that energy consumption in the bottleneck zone is reduced with the proposed approach. As a result this will lead to cause increase in network lifetime. Simulation results shows that there is an increase of 2.5% to 9.5% of network lifetime by using the proposed adaptive network coding based algorithm for 8% to 14% duty cycle respectively in a duty cycled WSN.

## ACKNOWLEDGEMENT

The author is deeply grateful to Prof A.N Mishra, for his kind advice, encouragement and help during the progress of work.

The authors are thankful to Shri Arun yadav for his assistance during this work. The project is sponsored by Department of Electronics & Communication, Krishna Engineering College Ghaziabad.

## REFERENCES

- [1] Heejung Byun, Junglok Yu, "Adaptive Duty Cycle Control with Queue Management in Wireless Sensor Networks," *IEEE Transactions on Mobile Computing*, vol. 12, no. 6, pp. 1214-1224, June 2013, doi:10.1109/TMC.2012.102
- [2] Rashmi Ranjan Rout, Soumya K Ghosh, "Enhancement of Lifetime using Duty Cycle and Network Coding in Wireless Sensor Networks," *IEEE Transactions on Wireless Communications*, 12(2), 656-667, February 2013.
- [3] Q Wang and T. Zhang, "Bottleneck zone analysis in energy-constrained wireless sensor networks," *IEEE Commun. Lett.*, vol. 13, no. 6, pp. 423-425, June 2009
- [4] Ahmed M. Khedr and Walid Osamy, and Dhrama P Agrawal, "Perimeter Discovery in Wireless Sensor Networks," *J. Parallel Distrib. Comput.*, Vol. 69, pp. 922-929, 2009.
- [5] Ahmed M. Khedr, Walid Osamy, "Mobility-assisted minimum connected cover in a wireless sensor network," *J. Parallel Distrib. Comput.* 72(7): 827-837 (2012).
- [6] D. Estrin, R. Govindan, J. Heidemann, S. Kumar, Next century challenges: scalable coordination in sensor networks, in: *Proceedings of the 5th Annual ACM/IEEE International Conference on Mobile Computing and Networking*, Seattle, Washington, USA, August 1999, pp. 263-270.
- [7] H. Yang and B. Sikdar, Optimal Cluster Head Selection in the LEACH Architecture, *IEEE International Conference on Performance, Computing, and Communications*, 2007, 93-100.
- [8] C. F. Hsin and M. Liu, "Randomly duty-cycled wireless sensor networks: dynamic of coverage," *IEEE Trans. Wireless Commun.*, vol. 5, no. 11, pp. 3182-3192, 2006.
- [9] Q. Wang and T. Zhang, "Bottleneck zone analysis in energy-constrained wireless sensor networks," *IEEE Commun. Lett.*, vol. 13, no. 6, pp. 423-425, June 2009.
- [10] S. Lee and S. H. Lee, "Analysis of network lifetime in cluster-based sensor networks," *IEEE Commun. Lett.*, vol. 14, no. 10, pp. 900-902, 2010.
- [11] M. Bhardwaj, T. Garnett, and A. Chandrakasan, "Upper bounds on the lifetime of sensor networks," in *Proc. 2001 IEEE ICC*, pp. 785-790.
- [12] H. Zhang and J. C. Hou, "On the upper bound of  $\alpha$ -lifetime for large sensor networks," *ACM Trans. Sen. Netw.*, vol. 1, no. 2, pp. 272-300, 2005.
- [13] H. R. Karkvandi, E. Pecht, and O. Y. Pecht, "Effective lifetime-aware routing in wireless sensor networks," *IEEE Sensors J.*, vol. 11, no. 12, pp. 3359-3367, 2011.
- [14] F. Wang and J. Liu, "RBS: a reliable broadcast service for large-scale low duty-cycled wireless sensor networks," in *Proc. 2008 IEEE ICC*, pp. 2416-2420.
- [15] Y. Gu, T. Zhu, and T. He, "ESC: Energy synchronized communication in sustainable sensor networks," in *Proc. 2009 IEEE Int. Conf. on Network Protocols*, pp. 52-62.
- [16] S. Lai and B. Ravindran, "Efficient opportunistic broadcasting over duty-cycled wireless sensor networks," in *Proc. 2010 IEEE INFOCOM*, pp. 1-2.
- [17] D. Kim, C. F. Hsin, and M. Liu, "Asymptotic connectivity of low duty-cycled wireless sensor networks," in *Proc. 2005 IEEE MILCOM*, pp. 2441-2447.
- [18] D. Lun, M. Medard, R. Koetter, and M. Effros, "On coding for reliable communication over packet networks," *Physical Commun.*, vol. 1, pp. 3-20, 2008.
- [19] R. R. Rout, S. K. Ghosh, and S. Chakrabarti, "A network coding based probabilistic routing scheme for wireless sensor network," in *Proc. 2010 Int. Conf. on Wireless Communication and Sensor Networks*, pp. 27-32.
- [20] R. Ahlswede, N. Cai, S. Y. R. Li, and R. Yeung, "Network information flow," *IEEE Trans. Inf. Theory*, vol. 46, no. 4, pp. 1204-1216, July 2000.
- [21] O. M. Al-Kofahi and A. E. Kamal, "Network coding-based protection of many-to-one wireless flows," *IEEE J. Sel. Areas Commun.*, vol. 27, no. 5, pp. 797-813, 2009.
- [22] M. Bhardwaj, T. Garnett, and A. Chandrakasan, "Upper bounds on the lifetime of sensor networks," in *Proc. 2001 IEEE ICC*, pp. 785-790.