

Obstacle Avoidance Robot

BACHELOR OF ENGINEERING IN COMPUTER ENGINEERING

By

Kirti Bhagat

Sayalee Deshmukh

Shraddha Dhonde

Sneha Ghag

Project Guide

Prof. Vijaya Waghmare

ABSTRACT-

The project is design to build an obstacle avoidance robotic vehicle using ultrasonic sensors for its movement. A micro-controller (AT mega 8) is used to achieve the desired operation.

A robot is a machine that can perform task automatically or with guidance. Robotics is a combination of computational intelligence and physical machines (motors). Computational intelligence involves the programmed instructions.

The project proposes robotic vehicle that has an intelligence built in it such that it directs itself whenever an obstacle comes in its path. This robotic vehicle is built, using a micro-controller of AT mega 8 family. An ultrasonic sensor is used to detect any obstacle ahead of it and sends a command to the micro-controller. Depending on the input signal received, the micro-controller redirects the robot to move in an alternate direction by actuating the motors which are interfaced to it through a motor driver.

KEYWORDS-

Robot, ATMEGA-8 microcontroller, Ultrasonic sensors, obstacle avoiding robot.

I. INTRODUCTION

Obstacle avoidance is a primary requirement of any autonomous mobile robot. Obstacle avoidance Robot

is design to allow robot to navigate in unknown environment by avoiding collisions.[1] Obstacle avoiding robot senses obstacles in the path, avoid it and resumes its running.

There are some very famous methods for robot navigation like wall-following, edge detection, line following. One of the commercial systems uses wall-following method on a floor cleaning robot for long hallways. [1] A more general and commonly employed method for obstacle avoidance is based on edge detection. A disadvantage with obstacle avoidance based on edge detecting is the need of the robot to stop in front of an obstacle in order to provide a more accurate measurement. All mobile robots feature some kind of collision avoidance, ranging from primitive algorithms that detect an obstacle and stop the robot in order to avoid a collision, using some sophisticated algorithms, that enable the robot to detour obstacles. The latter algorithms are more complex, since they involve detection of an obstacle as well as some kind of quantitative measurements concerning the obstacle's dimensions. Once these have been determined, the obstacle avoidance algorithm needs to steer the robot around the obstacle and resume motion toward the original target.

In this paper the steering algorithm ensures that the robot does not have to stop in front of an obstacle during its navigation.[2] Hence the robots may overcome some of the problems during navigation, which are discussed above and it can navigate smoothly during its operation avoiding the collisions. We have presented a basic algorithm and design which can be further improved depending upon the required applications.

II. EXISTING SYSTEM:

In simple robot, steering algorithm is used for robotic actions in which driver or a human being is

controlling the robot using remote. Here driver is present, who can see the obstacle and navigate robot accordingly.

III. PROPOSED SYSTEM:

The project proposes a autonomous robotic vehicle, In which no remote is used for controlling the robotic actions. It intelligently detects obstacles present on its path through the sensors, avoid it and take decision on the basis of internal code that we set for it.

The detail information is given in the following subtopics which will help you to understand the whole system and its design.

- BASIC DESIGN OF ROBOT**

This robot was built with an Arduino development board on which microcontroller is placed. Arduino board is connected with DC Motor through Motor driver board(pin10, pin11, pin12, pin13)which provide power to the actuators. Actuators are used to move robot in Forward, Backward, Left and Right directions.

The brief description of inputs pins for movement of robot is given in below in table.

Movement	Pin 10	Pin 11	Pin 12	Pin 13
Forward	1	0	0	1
Backward	0	1	1	0
Left	1	0	1	0
Right	0	1	0	1

The movement of robot will be stop whenever there is an obstacle is present on its path which can be detected by ultrasonic sensors. Ultrasonic sensors give time in length to the microcontroller as a input for further actions.

- SENSORS FOR OBSTACLE AVOIDANCE**

Varieties of sensors are available which can be used for the detection of obstacles.[3] Some of the very popular sensors are: Infrared sensors (IR),Ultrasonic sensors, Cameras, which can be used as a part of Computer Vision, Sonar. It can measure the distance in its field of view of about thousands to hundreds points

In the design of robot, we are using ultrasonic sensors for obstacle detection and avoidance.[3]The ultrasonic sensors continuously emits the frequency signals, when obstacle is detected this signals are reflected back which then considered as input to the sensor.

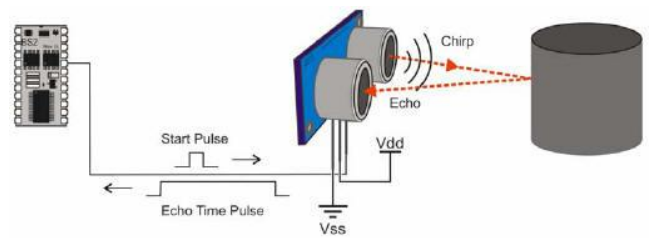

Fig.1: Schematic Diagram

The ultrasonic sensor consists of a multi vibrator, which fixed at its base. The multi vibrator is combination of a resonator and vibrator. The ultrasonic waves generated by the vibration are delivers to the resonator. Ultrasonic sensor actually consists of two parts: the emitter which produces a 40 kHz sound wave and detector which detects 40 kHz sound wave and sends electrical signal back to the microcontroller.[5]

In our project, we are using HC-SR04 ultrasonic sensors which consist of 4 pins VCC, Trigger, Echo and GND.[6]

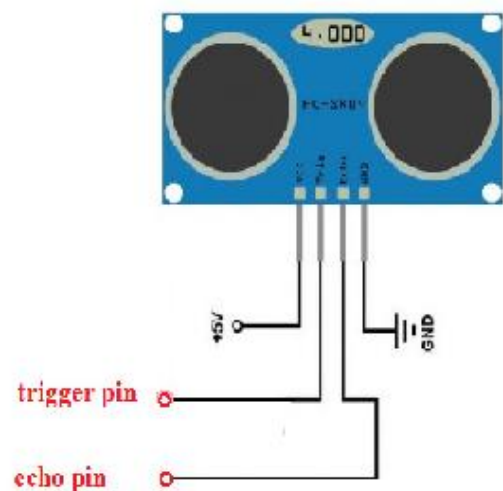

Fig.2: HC-SR04 Sensor Diagram

Features:

- Power Supply: +5V DC
- Working Current: 15mA
- Effectual Angle: <15degree
- Ranging Distance: 2cm – 400cm/1”-13ft
- Resolution: 0.3cm
- Measuring Angle: 30 degree
- Input pulse width: 10uS

• **ALGORITHM - WORKING PRINCIPLE**

The sonar system is used in HC-SR04 ultrasonic sensor to determine distance to an object like bats do. It offers excellent non-contact range detection from about 2 cm to 400 cm or 1'' to 13 feet. Its operation is not affected by sunlight or black material.[6]

The ultrasonic sensor emits the short and high frequency signal. If they detect any object, then they reflect back echo signal which taken as input to the sensor through Echo pin.[4]

Firstly we initialize Trigger and Echo pin as low and push the robot in forward direction. when obstacle is detected Echo pin will give input as high to micro-controller. pulseIn() function is used for calculating the time of distance from the obstacle. Everytime the function waits for pin to go high and starts timing, then timing will be stopped when pin go to low. It returns the pulse length in microseconds or when complete pulse was not received within the timeout it returns 0.[6]

The timing has been determined means it gives length of the pulse and will show errors in shorter pulses. Pulses from 10microseconds to 3 minutes in length are taken into consideration.

After determining the time, it converts into a distance. If the distance of object is moderate then speed of robot get reduced and will take left turn, If obstacle is present in left side then it will take right turn.

If the distance of object is short then speed of robot get reduced and will turn in backward direction and then can go in left or right direction.

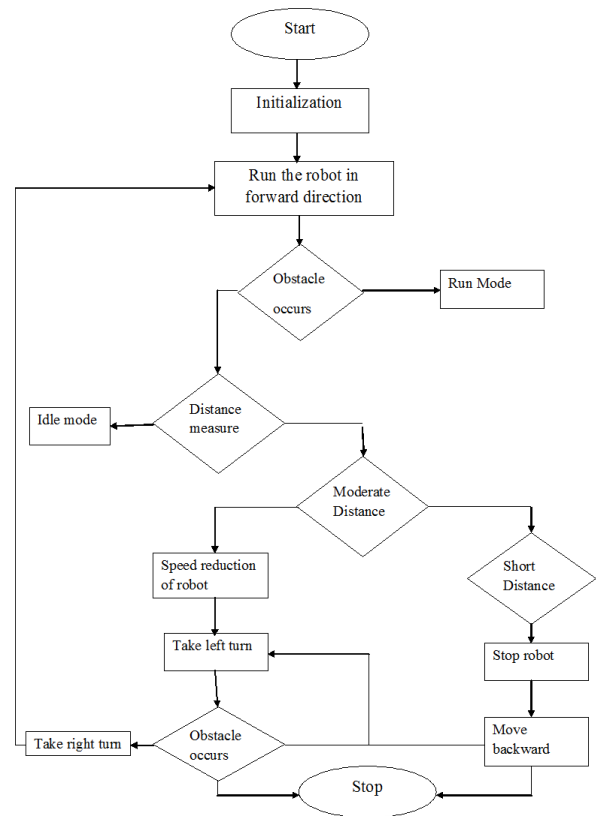

Fig.3: Obstacle Avoidance Flowchart

• **IMPLEMENTATION**

The implementation of obstacle avoidance strategy for robot involves the writing and compilation of program using Arduino software. Arduino is a popular programmable board used to create projects.[6]

It consists of a simple hardware platform on which microcontroller is placed as well as a free code editor which has a “one click compile or upload” feature. Hence it is designed for the peoples in such a way that they can use it without necessarily being an expert programmer.

Arduino offers an open-source electronic prototyping platform that is easy to use and flexible for peoples who are beginners in robotics field with both the software and hardware perspective.

The general block diagram for the complete execution is as Follow:

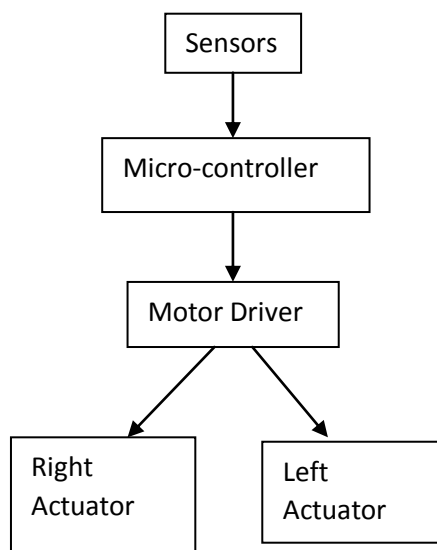

Fig.4: Block Diagram of obstacle avoidance robot

Sensors are connected with the Arduino board using breadboard. Microcontroller is able to sense the environment through receiving input from sensors. It is also able to control its surrounding through controlling motors and other actuators.[5]

The Arduino programming language that is based on the processing are used to program the microcontroller found on the board. Due to its open-source environment, we can able to easily write and upload codes to the I/Oboard. Arduinoenvironment is written in Javahence it can be run on Linux, Mac OSX and Windows platforms.

The output of the comparator is given to the microcontroller, which then moves actuators in left or right direction by giving power through DC motor.

IV. CONCLUSION

We build a robotic vehicle which moves in different directions like Forward, Backward, Left, and Right when input is given to it.

The goal of our project is to create a autonomous robot which intelligently detects the obstacle in his path and navigate according to the actions that we set for it.

V. REFERENCES

- [1] Obstacle avoidance robotic vehicle using ultrasonic sensors for obstacle detection : <http://www.elprocus.com/obstacle-avoidance-robotic-vehicle/>
- [2] How to make an obstacle avoiding robot: <http://www.instructables.com/id/How-To-Make-an-Obstacle-Avoiding-Arduino-Robot/>
- [3] IEEE paper for Obstacle avoidance robot using ultrasonic sensors: http://www.personal.umich.edu/~ykoren/uploads/Obstacle_avoidance_w_ultrasonic_sensors_IEEE.pdf
- [4] Obstacle avoiding robot without microcontroller: <http://www.roboticsbible.com/project-obstacle-avoiding-robot.html>
- [5] How to build an obstacle avoiding robot: <https://www.youtube.com/watch?v=JZ5JjvY1Eg>
- [6] Complete guide for Ultrasonic sensor HC-SR04 Tutorials: <http://randomnerdtutorials.com/complete-guide-for-ultrasonic-sensor-hc-sr04/>