

# A CONVERTER FOR BIPOLAR DC LINK BASED ON SEPIC-CUK COMBINATION FOR MICROGRID APPLICATIONS

Vattem Sri Divya\*, Ch Chinna Veeraiah\*\*

\* Department of EEE, Amrita Sai Institute of Science & Technology, Paritala, Krishna Dt, A.P, India

\*\* Department of EEE, Amrita Sai Institute of Science & Technology, Paritala, Krishna Dt, A.P, India

**Abstract-** The use of dc technology was almost discarded in the power transmission systems. DC power systems have been used in applications like avionic, automotive, marine, rural areas, telecommunication infrastructures and point-to-point transmissions over long distances or via sea cables and for interconnecting ac grids with different frequencies. This Paper describes a new application of single-ended primary converter (SEPIC) and Cuk converter for dc bipolar network. A dc-dc converter configuration based on a combination of both converters is proposed. In the resulting topology, the switching node is shared by the SEPIC and Cuk converter since they have the same instantaneous duty cycle. The main advantage of this topology is that synchronization of various switches is not required and control terminal is connected to ground which simplifies the design of the gate drive. On the other hand, this configuration allows the connection of renewable energy sources to microgrids (MG)-type bipolar dc link and to cover the current needs of new distributed generation units with efficient, economical, and easy way. To verify its performance, MATLAB/Simulink platform is used.

**Index Terms-** DC-link voltage balance, PMBLDCM, power quality (PQ), Air conditioner (AC).

## I. INTRODUCTION

The use of dc technology was almost discarded in the power transmission systems. DC power systems have been used in applications like avionic, automotive, marine, rural areas, telecommunication infrastructures and point-to-point transmissions over long distances or via sea cables and for interconnecting ac grids with different frequencies. Today's consumer equipment such as computers, fluorescent lights or LED lighting, households, businesses, industrial appliances, and equipment need the dc power for their operation. However, all these dc loads require conversion of the available ac power into dc for its performance. The majority of these conversion stages typically use inefficient rectifiers. On the other hand, most of renewable energy units generate in dc form or they have outputs voltage/frequency variable, which requires power electronic devices to adapt its output to network conditions. These dc-ac-dc power conversion stages result in substantial energy losses. Therefore, in many cases, it is justified to use dc microgrids since it would avoid all this conversions. DC microgrids have mainly the following advantages over ac microgrids [1]–[5]: more efficiency and more power transmission, require few wires, more stable, no reactance in the line, frequency is zero (so no need of frequency monitoring), no transient stability problems, no electromagnetic interference, and have lower line resistance. In a dc microgrid, energy can be transmitted with single cable, two

cables, or even three cables, what leads to consider three dc-link types: Monopolar, Bipolar, and Homopolar. Of all these topologies, bipolar dc link is one of the most used. Bipolar dc link has two wires (see Fig. 1): one with positive polarity and one with negative polarity. In normal operation, the current through ground is zero. It has two voltage levels allowing fault conditions a monopolar operation.

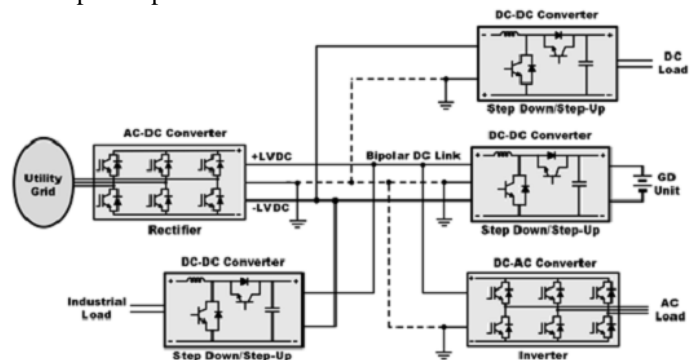

Fig. 1. Bipolar dc link.

It is also possible a metallic return with appropriate control strategies. This topology has a higher technical complexity and cost than the monopolar dc link, but has going for it the following advantages: the current through the return wire in normal operation is smaller, so the power losses are reduced; when a failure occurs in one of the lines, the other continues to operate normally; for the same transmission power, in a bipolar dc link, the current is half; and this topology allows to have two different voltage levels. This is useful when some loads consume high power because the current drawn is reduced. On the other hand, some renewable energy units generate in a dc way, so it is necessary to use dc-dc converters for connection to the appropriate network conditions. For bipolar dc link [6], these units use two or four controlled switches depending on whether it is a half-bridge and full-bridge converter. The advantages of microgrids are causing an increasing number of networks with this topology in the world. Initially, it was used in large data center, such as the Intel Corp., in USA with a bipolar dc link of  $\pm 200$  V or UPN AB of IBM in Sweden of  $\pm 190$  V, with power greater than 5 MW. Today, its applications are expanding dc distribution networks in low voltage (voltage below 1 kV) which include distributed generation since bipolar dc link has proven advantageous from the point of view of efficiency. In this paper, a new application of SEPIC and Cuk converters in low-voltage bipolar-type dc microgrid is presented by means the combining of both configurations. Main advantage is that with an only switch it is not necessary synchronization among switches.

Moreover, the control terminal is connected to ground which simplifies the construction of the gate drive.

## II. PROPOSED CONFIGURATION

DC-DC converters are widely known that can increase or decrease the magnitude of the dc voltage and/or invert its polarity. This is accomplished by the pulse width modulation (PWM) technique, usually to a constant frequency. Switching dc-dc converters are important power electronics systems widely used in a huge applications variety [7]–[9]. Several conventional single inductor dc-dc converters, such as buck, boost, canonical switching cell, and buck-boost single inductor converters, and also well-known two-inductor topologies, Cuk, SEPIC, and Zeta converters have been studied from different viewpoints (voltage gain, operating principle, voltage and current stress, and efficiency) for years [10], [11]. The combinations of these basic converters, such as boost-buck-cascaded converter and buck-boost-cascaded converter (two-switch topologies) [12], and buck-boost-zeta converter, SEPIC-boost converter, zeta-flyback converter [13], and SEPIC-Cuk converter have also described in the literature. An interesting combination of SEPIC and Cuk converter provides the ability to be used to create two outputs with the same voltage but with different polarities. This is particularly useful for powering the two rails in a low-voltage bipolar-type dc microgrid. An individual analysis of each topology gives some advantages and disadvantages for this application. The conventional SEPIC and Cuk converters (see Fig. 2) are formed by two inductors ( $L_1$  and  $L_2$ ), link capacitor ( $C_1$ ), switch ( $S_1$ ), and diode ( $D$ ). The Cuk is a negative output converter, while the SEPIC is a positive output converter. Assuming SEPIC and Cuk converters without losses, and that the switching ripple magnitudes are small compared to their respective dc components, the relation between the input voltage and the output voltage can be obtained both in continuous-conduction mode (CCM) and in discontinuous conduction mode (DCM). CCM means that the current through the inductor is continuous, while in DCM, this current is discontinuous. CCM is preferred for high efficiency and good utilization of the converter switches and passive components. Both

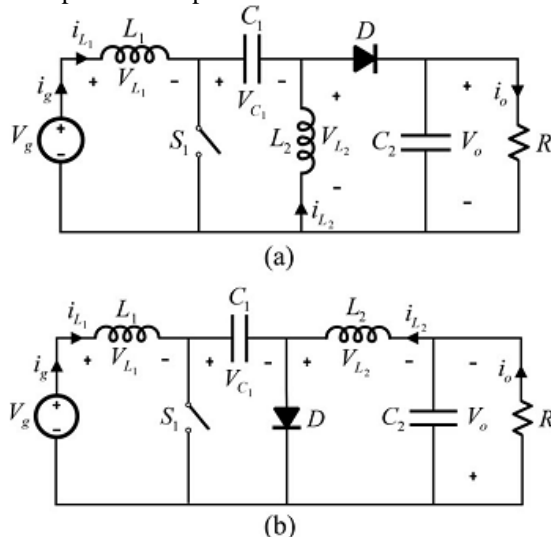

Fig. 2. SEPIC and Cuk converters. (a) SEPIC converter. (b) Cuk converter.

converters provide the same conversion relation given by

$$V_o(\text{CCM}) = |V_g| \frac{D}{1-D} \quad \text{and} \quad I_g(\text{CCM}) = I_o \frac{D}{1-D} \quad \dots(1)$$

$$V_o(\text{DCM}) = D \cdot |V_g| \sqrt{\frac{R \cdot T_S}{2 \cdot L_{\text{eq}}}}$$

$$\text{and } I_g(\text{DCM}) = D \cdot I_o \sqrt{\frac{R \cdot T_S}{2 \cdot L_{\text{eq}}}}$$

where  $\frac{1}{L_{\text{eq}}} = \frac{1}{L_1} + \frac{1}{L_2}$ ; DCM occurs for :

$$\frac{2 \cdot L_{\text{eq}}}{(1-D)^2 R \cdot T_S} < 1. \quad \dots\dots(2)$$

The duty cycle (D) is the ratio of the conduction time (TON) to the switching period (TS). Both topologies present very similar characteristics: They use the same number of components, submit the same stresses to the power switches, and provide similar efficiency. From an analytical point of view, Cuk and SEPIC topologies are also similar. However, in the SEPIC converter, the average voltage across capacitor C1 ( $V_{C1}$ ) is equal to the input voltage ( $V_g$ ), while in the Cuk converter, the voltage at the capacitor C1 is the addition of input and output voltage ( $V_g + V_o$ ). Therefore, the size of this capacitor in the SEPIC converter can be smaller than the Cuk converter. In both topologies, input currents are non pulsating. On the other hand, the output current is non pulsating in the Cuk converter and it is pulsating in the SEPIC converter. If SEPIC and Cuk configurations are compared, it is observed that have identical front end. Both converters have the same voltage conversion ratio with opposite polarities. Hence, it is possible to combine the two structures to build a bipolar-type converter, as it is shown in Fig. 3. As can be seen, the two combined structures share a common ground reference switch and an equivalent inductor at the input. The main advantage of the proposed configuration is that it allows implementation bipolar dc link with only one controllable switch, which simplifies the implementation of control strategies since it is not necessary

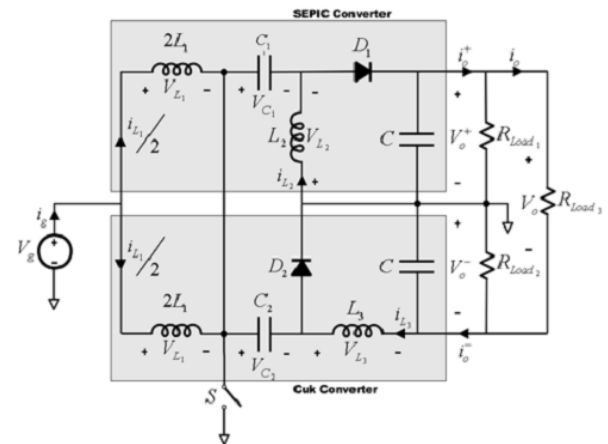

Fig. 3. SE-CuCC.

synchronization of various switches. Moreover, control terminal is connected to ground which simplifies the implementation of the gate drive. In a static way, the circuit operates as follows (see Fig. 3). When the switch S is turned ON, the energy supplied by the generator is stored in L1 (where L1 is equivalent inductance of the two inductors at the input with value 2L1); inductors L2 and L3 also stored energy due to the discharge of C1 and C2. During this interval, the freewheeling diodes (D1 and D2) are OFF and the energy supplied to the loads is provided by the output capacitors labelled with C. When the switch S is turned OFF, inductors recharge capacitors C1 and C2 through the freewheeling diodes (D1 and D2) and supply power to the loads. From Fig. 3, the performance of SE-CuCC can be evaluated in terms of devices stress, low input ripple, and size of magnetic components [12]. It is assumed that SE-CuCC is operating in CCM. Table I summarizes aforementioned properties. Note as the SEPIC side requires a larger current across inductor L2, moreover, Cuk side requires a larger voltage across capacitor C2. The inductor L1 and the switch can be operated in parallel for higher power ratings and can be easily reconfigured to obtain different ratings.

### III. SIMULATION RESULTS

The proposed cuk, sepic and secucc converters performance is studied in MATLAB/SIMULINK platform. The fig 4(a), (b) and (C) shows the simulated circuit of cuk, sepic and secucc converter. The switched boost inverter output line to line voltage and current, stator current and back EMF of motor, speed and torque of motor are presented .it is observed that the inverter output and currents are having the THD of 1.92%.the speed of the PMSM controlled by controlling dc bus voltage. The time delay of 0.1sec is allowed in the simulation to study the starting characteristics of the Motor.

#### A. Simulation circuit of cuk converter

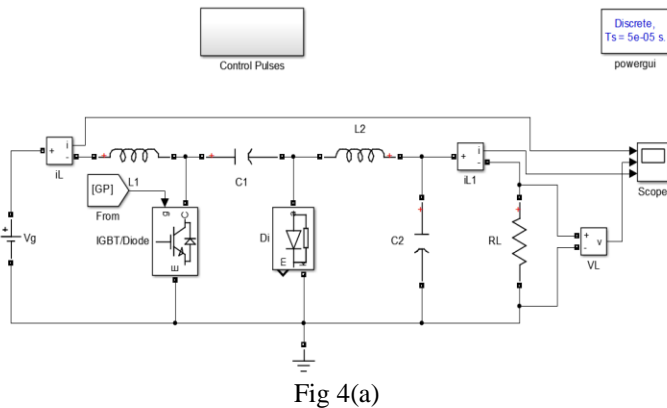

Fig 4(a)

#### B. Simulation Circuit of sepic converter

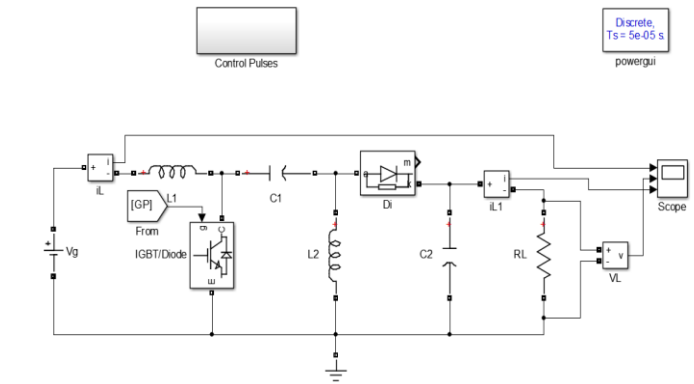

Fig 4(b)

#### C. Simulation Circuit of secucc converter

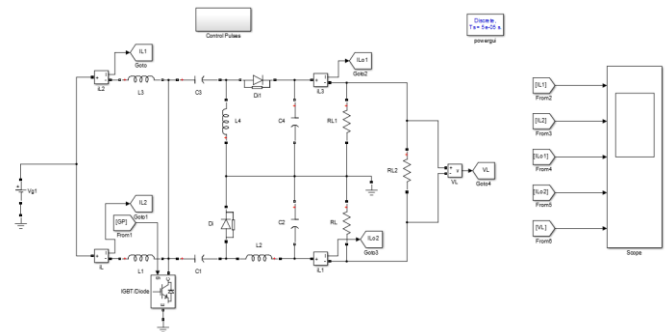

Fig 4(c)

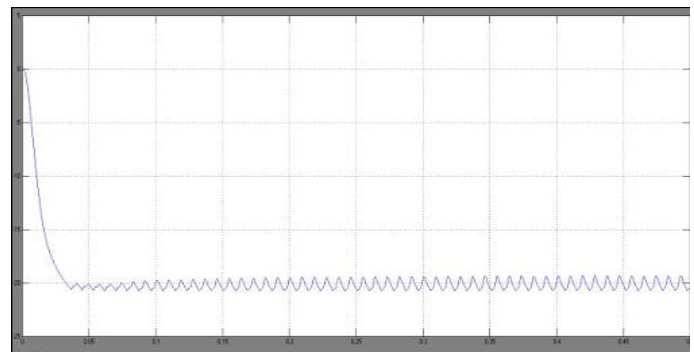

Fig 5:cuk output current

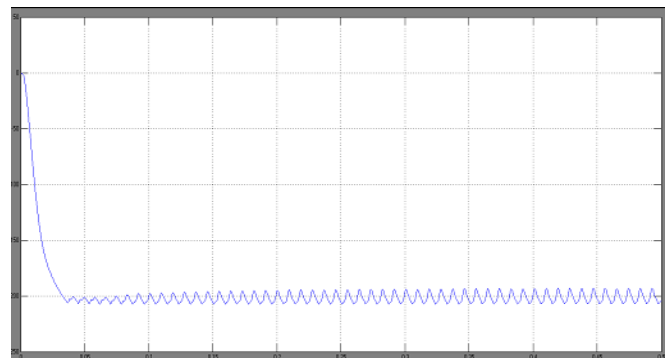

Fig6:cuk output voltage

#### IV. CONCLUSION

In this paper, a converter prototype for dc microgrid applications has been presented. This converter consist the combination of SEPIC and Cuk topologies (SE-CuCC). Both converters have the same voltage conversion ratio with opposite polarities. Therefore, it is possible to combine the two topologies to build a bipolar-type converter. The two combined structures share a common ground reference switch, and an equivalent inductor at the input. The main advantage of the proposed configuration is that it allows implementation bipolar dc link with only one controllable switch, which simplifies the implementation of control strategies, since it is not necessary synchronization of various switches. Moreover, control terminal is connected to ground which simplifies the implementation of the gate drive. An experimental prototype has been developed and subjected to changing load conditions. Experimental results show its voltage regulation capacity even in unbalance cases. The proposed SE-CuCC allows us to cover the current needs in new distributed generation units with economical and easy way. Highlighting three aspects of the prototype developed: simple structure since it uses an only switch and fewer passive elements, a driver circuit more simple due to there is only one switch to be controlled and it does not require isolation, and control circuit is simpler since they can be regulated dc bipolar voltages with an only controller.

#### REFERENCES

- [1] J. J. Justo, F. Mwasilu, J. Lee, and J. W. Jung, "AC-microgrids versus DC-microgrids withy distributed energy resources: A review,"Renew. Sustainable Energy Rev., vol. 24, pp. 387–405, 2013.
- [2] H. Kakigano, Y. Miura, and T. Ise, "Low-voltage bipolar-type DC microgrid for super high quality distribution,"IEEE Trans. Power Electron.,vol. 25, no. 12, pp. 3066–3075, Dec. 2010.
- [3] J. C. Vasquez, J. M. Guerrero, J. Miret, M. Castilla, and L. Vicu~ na, "Hierarchical control of intelligent microgrids,"IEEE Ind. Electron. Mag.,vol. 4, no. 4, pp. 23–29, Dec. 2010.
- [4] S. R. Huddy and J. D. Skufca, "Amplitude death solutions for stabilization of DC microgrids with instantaneous constant-power loads,"IEEE Trans. Power Electron., vol. 28, no. 1, pp. 247–253, Jan. 2013.
- [5] H. Kakigano, Y. Miura, and T. Ise, "Distribution voltage control for DC microgrids using fuzzy control and gain-scheduling technique,"IEEE Trans. Power Electron., vol. 28, no. 5, pp. 2246–2258, May 2013.
- [6] J. Lago, J. Moia, and M. L. Heldwein, "Evaluation of power converters to implement bipolar dc active distribution networks—DC–DC converters," inProc. Energy Convers. Congr. Expo., 2011, pp. 985–990.
- [7] R.-J. Wai and K.-H. Jheng, "High-efficiency single-input multiple-output DC–DC converter,"IEEE Trans. Power Electron., vol. 28, no. 2, pp. 886– 898, Feb. 2013.
- [8] P. Patra, A. Patra, and N. Misra, "A single-inductor multiple-output switcher with simultaneous buck, boost and inverted outputs,"IEEE Trans. Power Electron., vol. 27, no. 4, pp. 1936–1951, Apr. 2012.

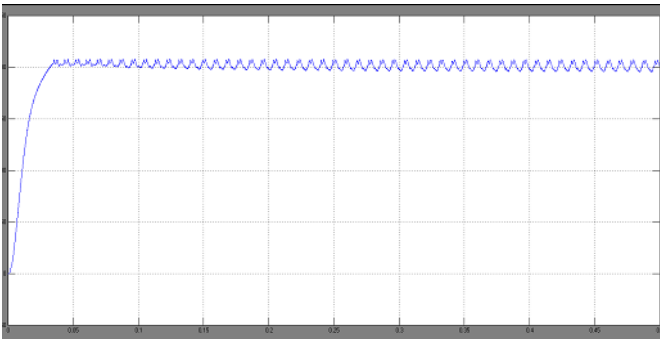

Fig 7: sepic output current

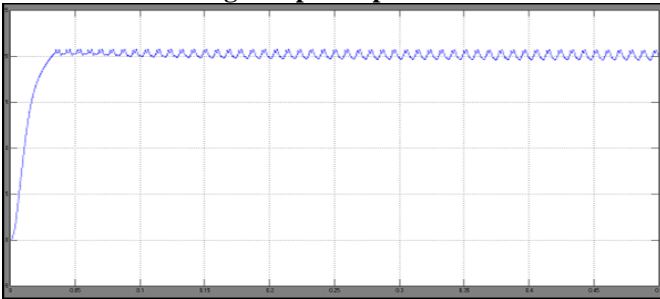

Fig 8: sepic output voltage

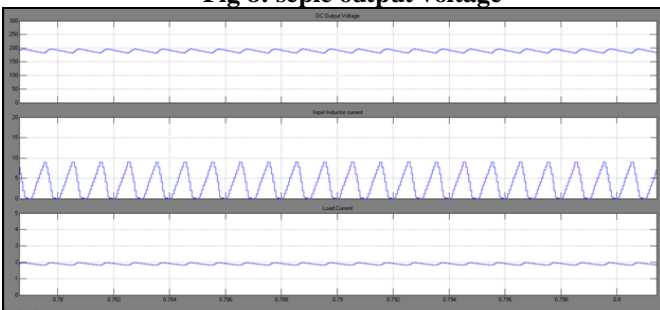

Fig 9 Load current

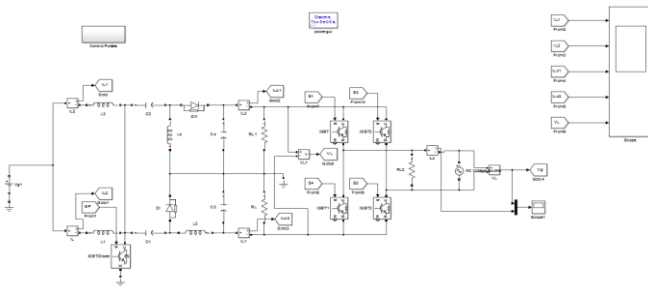

Fig 10 Grid connected SeCuCC

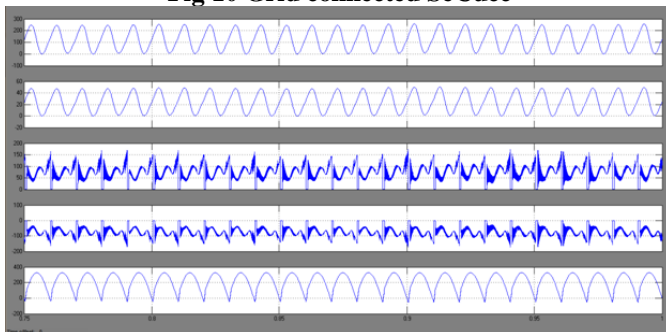

Fig 11 Grid connected Secucc results

- [9] X. Yu, K. Jin, and Z. Liu, "Capacitor voltage control strategy for halfbridge three-level DC/DC converter," IEEE Trans. Power Electron., vol. 29, no. 4, pp. 1557–1561, Apr. 2014
- [10] E. Landsman, "A unifying derivation of switching DC-DC converter topologies," in Proc. IEEE Power Electron. Spec. Conf., PESC1979, pp. 239–243.
- [11] D. Maksimovic and S. Cuk, "General properties and synthesis of PWM DC-to-DC converters," in Proc. IEEE Power Electron. Spec. Conf., PESC1989, pp. 515–525.
- [12] E. Duran, M. Sidrach-de-Cardona, J. Galan, and J. M. Andujar, "Comparative analysis of buck-boost converters used to obtain I–V characteristic curves of photovoltaic modules," in Proc. IEEE Power Electron. Spec. Conf., 2008, pp. 2036–2042.
- [13] B. R. Lin and F. Y. Hsieh, "Soft-switching Zeta-flyback converter with a buck-boost type of active clamp," IEEE Trans. Ind. Electron., vol. 54, no. 5, pp. 2813–2822, Oct. 2007.

## AUTHORS

**First Author** – Vattem Sri Divya, she received her B.Tech degree in Electrical and Electronics Engineering from Malineni Lakshmaiah Women's Engineering College in 2013. She is currently pursuing M.Tech Power Electronics in Amrita Sai Institute of Science and Technology, Paritala, A.P, India. His interested research areas are Power Electronic Applications to Power systems.



**Second Author** – Ch Chinna Veeraiah, he received his B.Tech degree in Electrical and Electronics Engineering from VRS &YRN College of Engineering and Technology, Chirala (A.P), India, in 2008. M.Tech degree in Power Electronics from VRS &YRN College of Engineering and Technology, Chirala (A.P), India, in 2013. He is currently working as a Assistant Professor in Amrita Sai Institute of Science and Technology, Paritala, A.P, India. His interested research areas are Power Electronics and Power Systems

