

Review of Reduction of PAPR in OFDM system using DCT Preceded SLM Technique

Rupesh Kumar
Department of ECE
Bhopal Institute of Technology,
Bhopal, India-462045
Email- rupeshkumarece@gmail.com

Prof. Gulab Singh Vaishya
Department of ECE
Bhopal Institute of Technology,
Bhopal, India-462045
Email- gulab_vaishya@yahoo.co.in

Abstract: - The high PAPR in an OFDM system arises because of IFFT operation, where data symbol across subcarrier can add up to produce a high peak value signal. In OFDM system, the peak deviation about average is significantly high, hence the signal level moves outside the dynamic range. Because in OFDM system we are loading the symbol in subcarrier and then take IFFT of this signal. This arises high PAPR, which limits use of OFDM in latest technological advancement such as 4G and 5G. This paper presents an idea to reduce PAPR in OFDM system using selected mapping (SLM) technique. When we want to convert a finite sequence of data points in terms of a sum of cosine functions oscillating at different frequencies we need to apply Discrete Cosine Transform(DCT), and it is easiest way to do so.

Keywords: OFDM, PAPR, SLM, DCT, IFFT, CR

INTRODUCTION

As technology advances high data rate is needed for different types of wireless applications, demand of the spectrum is rapidly increasing. Now a day's government and different types of regulating agencies impose strict regulations on spectrum utilization by different types of regulations such as control of allocations and priorities, as well as its features. At present time, nearly all of standard spectrum has been assigned and it is difficult to find spectrum for the new wireless applications. Spectrum can be made available for either expand existing infrastructures or to start new services for new connections. Presently all spectrum allocated to first come first serve basis and is using by its current retainer it is either government, commercial, telecom company. They are primary users and in their usages there exist a lot of spectrum's reutilization aspects, which can be easily used by secondary users. Different international agencies and researchers are working on the concept of dynamic spectrum access, where secondary users can borrow unused portions of the spectrum from primary users. Cognitive Radio (CR) is employing due to adaptability and flexibility for their proper utilization. Orthogonal

Frequency Division Multiplexing (OFDM) is widely used in field of wireless communication as spectrum is limited and demand of mobile communication is expanding day by day [31]. In wireless communication, the constrained range of assets is amazingly significant. Spectrum resources determine the system to oblige the number of clients, in this manner influencing the network construction, market positioning and a progression of key strategies. Enhance spectrum efficiency is especially important for the development of mobile communication, multiple access technology is one of the solutions to the shortage of spectrum resources [1]. Strong anti-fading ability, high spectral efficiency, good narrow band interference performance and other advantages make OFDM technology, once again aroused people's attention [2]

With the improvement and innovation of science and technology, utilizing the discrete Fourier transform and inverse discrete Fourier transform to accomplish the objective of the modulation and demodulation of OFDM framework, enormously decrease the amount of calculation[3]. However, high PAPR limits the wide utilization of OFDM technology, which straightforwardly influences the activity cost and effectiveness of the entire system [3]. High PAPR signals not only have necessity for the linear dynamic range of the power amplifier, but also the precision of the analog-to-digital converter / digital-to-analog converter. If it does not then signal distortion, serious interference, reduce the energy efficiency of the terminal and more disadvantages will show. The effective suppression of PAPR in OFDM is must.

OFDM is a combination of modulation and multiplexing. Multiplexing is generally refer to many to one and modulation is process to transmit the information.[5] In OFDM the signal split into independent channel, modulated by data and then again multiplexed to create carrier OFDM is special case of Frequency division multiplexing (FDM). As an Analogy, a FDM channel is like water flow out of a pipe, in contrast the OFDM signal is like a Shower. One of the challenges of the OFDM is high peak-to-average power ratio (PAPR) A high PAPR has many disadvantages as reduced efficiency of radio frequency (RF) power and amplifier

and an increased complexity of the A/D and D/A converters [53]. OFDM signal has a large number of independent modulated subcarriers that is the reason which may leads to the problem of PAPR. If all subcarriers come with same phase, the peak power is N times the average power of the signal where N is the total number of symbols in an OFDM signal. . Hence, because of that reason it not possible to send this high peak amplitude signals to the transmitter without reducing peaks. Because power amplifier used for the transmission has non-linear nature which causing inter-modulation and out-of-band radiation. The high peak problem of OFDM signal can be overcome in many ways.

OFDM and PAPR Reduction Methodology

High PAPR reduced method has been studied in OFDM, which can be classified into three categories according to the different operation of the application: clipping technology (for example: the clipping method, the peak offset, etc.), coding technology (for example: block code, complementary and gray code, etc.) and probability technology (for example: selected mapping, partial transmit sequence).[6] Various techniques in the suppression of PAPR will also exist corresponding defects. Clipping constraints of clipping technique will cause the signal distortion, in-band aliasing phenomenon, deteriorating the bit error rate and spectral efficiency of the transmission system; coding technology limits the number of code words used to encode the signal, when the number of subcarriers is large, the complexity of encode and decode is high and signal rate decreases rapidly; probability technology reduces the probability of high PAPR, and generates sideband information, which leads to the decrease of system throughput[7]. Therefore, the combination of various technical advantages and disadvantages of the joint algorithms are also emerging, such as: partial transmit sequence and quantization of clipping, clipping and commanding, etc. Base on the relationship between the PAPR of the OFDM signal and autocorrelation function of the input data sequence.

The transmitter, the transmitter of the OFDM maps the data bit stream into a symbol sequence, this can be done by serial/parallel devices, forming multiple parallel low sub-symbol streams, input digital signal is modulated by different subcarriers[8]. After series/parallel transformation of the high-speed data streams, the symbol rate is greatly reduced, and the symbol period is moderately extended, which can effectively resist the inter symbol obstruction. Dissimilar to conventional multicarrier modulation techniques, multiple orthogonal subcarriers of OFDM can overlap each other with the goal that that the spectrum is fully used(as appeared in Fig (1))[8]. The tail of each OFDM symbol is duplicated to the front of the symbol as a insurance interval, which can eliminate interfere between OFDM symbols, and can

also enhance subcarrier scrambling. In an OFDM obstruct, the info information can be expressed as: OFDM modulation signal can be expressed as:

In OFDM framework, as appeared in fig.1, a settled number of progressive information test are modulated first (e.g., Quadrature Phase Shift Keying), and afterward combined together utilizing IFFT at the transmitter side. IFFT is used to produce orthogonal data subcarriers. Let data block of length N be represented by a vector

$$X = [X_0, X_1, \dots, X_{N-1}]^T \quad (1)$$

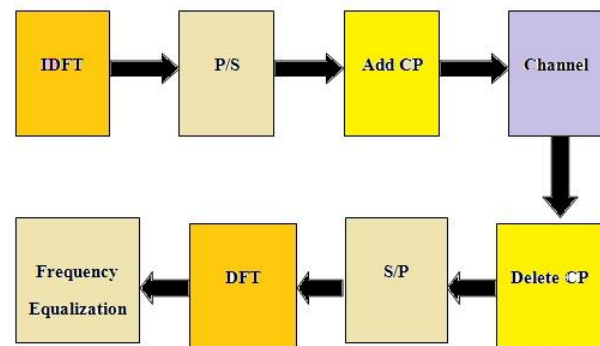

Fig 1. Block Diagram of OFDM System

Where X_k is the duration of a symbol x in the set X is T and represents one of the sub-carriers set. OFDM signal to be transmitted in form of complex data block is given by

$$x(t) = \frac{1}{\sqrt{N}} \sum_{n=0}^{N-1} X_n e^{j2\pi n \Delta f t} \quad 0 \leq t \leq NT \quad (2)$$

Here $j = \sqrt{-1}$ and Δf is spacing between subcarrier and NT is block period for useful data block.

The use of a large number of subcarriers introduces a high PAPR in OFDM systems.[10] PAPR can be defined as the relationship between the maximum power of a sample in a transmit OFDM symbol and its average power. Coherent addition of N signals of same phase produces a peak which is N times the average signal.[11] PAPR can vary up to its theoretically maximum of 10(dB), where N is the number of subcarriers.

$$PAPR = \frac{\max|x(n)|^2}{E[|x(n)|^2]} \quad (3)$$

Where $|x(n)|$ is the magnitude of x(n) and E[.] denotes the expectation operation.

PAPRs at the transmitter are driven into saturation due to high PAPR, degrading the BER performance. To avoid driving the PAPR into saturation, the average power of the signal may be reduced. However, this reduces the SNR and, consequently, the BER performance. Therefore, it is preferable to solve the problem of high PAPR by reducing the peak power of the signal. Many PAPR reduction techniques have been proposed. The two main factors can demonstrate the performance of PAPR reduction scheme is given by bit error rate (BER) and the complementary cumulative distributive function (CCDF).

PROPOSED MODEL (SLM Based OFDM System)

Selective mapping (SLM) is a simple approach to reduce PAPR[12]. In this method, a set of sufficient different OFDM symbols $x_m, 0 \leq m \leq M - 1$ are generated, each of length N, all representing the same information as that of the original OFDM symbol x, then the one with the least PAPR is transmitted. Mathematically, the transmitted OFDM symbol.

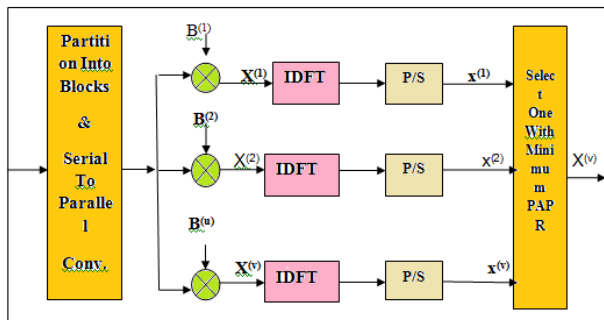

Fig. 2 Block Diagram of SLM Based OFDM System

Fig. 2 represents a block diagram of the SLM-OFDM system. Every data block is multiplied by V dissimilar phase sequences, each of length equal to N, $B^{(v)} = [b_{v,0}, b_{v,1}, \dots, b_{v,N-1}]^T (v=1,2, 3, \dots, V)$ which results in the changed data blocks. The phase sequence for altered data block is given by $X^{(v)} = [X_0 b_{v,0}, X_1 b_{v,1}, \dots, X_{N-1} b_{v,N-1}]^T$. Each $(v=1,2, \dots, V)$ can be defined as

$$X_n^v = X_n b_{v,n} (1 \leq v \leq V) \quad (4)$$

The OFDM signal becomes as follows, after applying SLM to X,

$$x_n^v = \frac{1}{\sqrt{N}} \sum_{k=0}^{N-1} X_k^v e^{j2\pi \left(\frac{n}{N}\right)k} \quad (5)$$

where, $n = 0, 1, \dots, N - 1$,

$$v = 1..V$$

The PAPR of OFDM signal in (5) can be written as

$$PAPR = \frac{\max |x_n^v|^2}{E[|x_n^v|^2]} \quad (6)$$

Amongst the tailored data blocks $X^v, v = 1, 2, \dots, V$, the data block with the least PAPR is chooses for transmission and as a side information the information about selected phase sequence must be sanded to the receiver. To recover the actual data block at receiving end we performed operation in reverse order.

DCT Precoder Based OFDM System

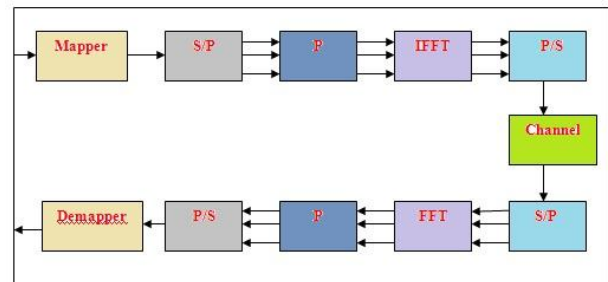

Fig.3 Block Diagram of Precoding Based OFDM System

Fig. 3 shows a precoding based OFDM system. In this system a precoding matrix P of dimension N x N is constructed which is based on DCT. P is applied to constellations symbols before IFFT to reduce the PAPR. DCT matrix P of size N-by-N can be created by using equation (7)

$$D_{i,j} = \begin{cases} \frac{1}{\sqrt{N}} & i = 0 \quad 0 \leq j \leq N - 1 \\ \sqrt{\frac{2}{N}} & 0 \leq j \leq N - 1 \end{cases}$$

And DCT can be defined as

$$X(K) = \sum_{n=0}^{N-1} \cos \left[\frac{\pi}{N} \left(n + \frac{1}{2} \right) k \right] \quad (7)$$

Where $K = 0, 1, \dots, N - 1$ In precoding based OFDM system baseband modulated data is passed through S/P convertor which generates a complex vector of size N that can be written as. Then precoding is applied to this complex vector which transforms this complex vector

into new vector of length that can be written as $Y=PX=[Y_0, Y_1, \dots, Y_{N-1}]^T$, Where P is a DCT based precoding Matrix of size $M = N \times N$ With the use of reordering as given in equation (8)

$$K = mN + n \quad (8)$$

Matrix P can be written as

$$P = \begin{bmatrix} p_{00} & p_{01} & p_{0(N-1)} \\ p_{10} & p_{11} & p_{1(N-1)} \\ \dots & \dots & \dots \\ p_{(N-1)0} & p_{(N-1)1} & p_{(N-1)(N-1)} \end{bmatrix} \quad (9)$$

Again, Y can be obtained by precoding of X as follows:
 $Y = PX \quad (10)$

$$Y_m = \sum_{i=0}^{N-1} p_{m,i} X_n \quad (11)$$

$p_{m,i}$ Means lth row and mth column of precoder matrix. The baseband OFDM signal with N subcarriers in complex form can be written as

$$x_n = \frac{1}{\sqrt{N}} \sum_{m=0}^{N-1} Y_m \cdot e^{j2\pi \left(\frac{n}{N}\right)m} \quad (12)$$

$n = 0, 1, \dots, N - 1$

The PAPR of OFDM signal in (12) can be written as

$$PAPR = \frac{\max |x(n)|^2}{E[|x(n)|^2]} \quad (13)$$

The block diagram of the proposed DCT Precoder based SLM-OFDM system can be shown in fig. 5. Suppose data stream after Serial to parallel conversion is $X = [X_0, X_1, \dots, X_{N-1}]^T$ and each data block is multiplied by V dissimilar phase sequences, each length equal to N, $B^{(v)} = [b_{v,0}, b_{v,1}, \dots, b_{v,N-1}]^T$, ($v = 1, 2, \dots, V$), which results in the altered data blocks. Let us denote the altered data block for the vth phase sequence is given by

$$X^{(v)} = [X_0 b_{v,0}, X_1 b_{v,1}, \dots, X_{N-1} b_{v,N-1}]^T$$

$v = (1, 2 \dots V)$

Each X_n^v can be defined as

$$X_n^v = X_n b_{v,n} \quad (1 \leq v \leq V)$$

Now we pass the signal given in equation (11) through our DCT Precoder based Precoder and resultant flag can be composed as

$$Y_m^v = \sum_{i=0}^{N-1} p_{m,n} X_n^v, \quad m = 0, 1, N - 1 \quad (14)$$

Where $p_{m,n}$ means precoding matrix of nth row & mth column the signal in equation (11) after performing the IFFT can be written as

$$x_n^v = \frac{1}{\sqrt{N}} \sum_{m=0}^{N-1} Y_m^v \cdot e^{j2\pi \left(\frac{n}{N}\right)m} \quad (15)$$

Where $N=0, 1 \dots N-1$

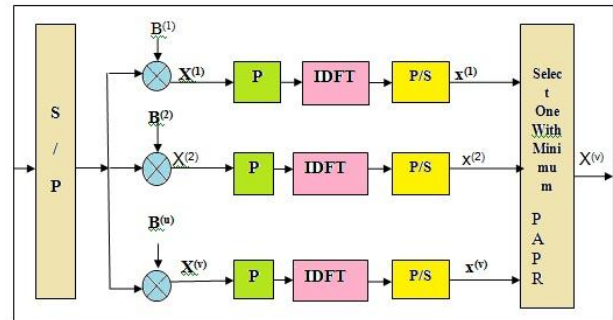

Fig. 4 Block Diagram of DCT Precoder based SLM-OFDM System

Where $v = (1, 2, \dots, V)$ And the PAPR of OFDM signal in (18) could be composed as

$$PAPR = \frac{\max |x_n^v|^2}{E[|x_n^v|^2]} \quad (16)$$

Results Analysis

The framework here displayed is utilizing Matlab to consider the impact of SLM-DCT based PAPR reduction system. The point of doing the simulations is to assess the execution of PAPR reduction techniques. Distinctive parameters utilized as a part of the system. Simulation figure is given in Figure 5. Recreation is done under the supposition that proper synchronization is kept up between the transmitter and the receiver. The length of the cyclic prefix is been more noteworthy than the most extreme delay spread as in order to avoid inter symbol interference. Re-enactments are done for various signal-to-noise ratios.

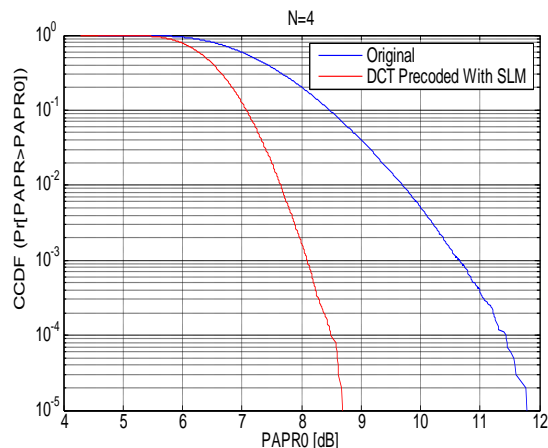

Fig 5: CCDF of OFDM system with DCT Pre coded with SLM technique.

From the simulation graph we draw the following Conclusions Table:

Table I

CCDF	PAPR(Original SLM) (dB)	PAPR (DCT with SLM) (dB)
10^{-3}	10.62	8.095

Analysis

At 10^{-3} value of CCDF, we get value of PAPR which is 10.62 dB in case of original SLM, while in case of DCT with SLM is 8.095 dB. So we can see here reduction in PAPR of the system, while at the value of 10^{-5} we get approximately 3 dB improvements in PAPR.

Conclusion

OFDM is an exceptionally appealing strategy for multicarrier transmission and has turned to be one of the standard decisions for high rapid data transmission over a communication channel. It has different favorable circumstances; yet in addition has one major drawback: it has a very high PAPR. In this paper portion of the strategies for reducing the high PAPR of the system were dissected and thought about. Among the five techniques that were analyzed, it was found out that peak insertion is more effective in PAPR reduction. Anyway no particular PAPR diminishment strategy is the best answer for the OFDM framework. When we go for PAPR technique, we should care of loss of information; transmit signal power increase, BER increase, and computational complexity increases. Here, only one Input one Output (SISO) OFDM framework have been considered. It can be reached out to MIMO OFDM which can be actualized using multiple transmitting and receiving antennas which is an interesting work of future.

Acknowledgment

Authors would like to thank Dr. Shilpi Sharma, HOD of ECE Branch, Bhopal Institute of Technology for guidance and valuable suggestions. We also like to thank our beloved Smt. Supriya Kumari and Smt. Laxmi Kumari for their sincere efforts in completing this research paper.

Reference

- [1] M.G. Sumithra and M.Sarumathi, "PAPR Reduction Techniques for Multicarrier Systems," in *Global Trends in information Systems and Software Applications*, Vol. 270, pp.52-55.
- [2] P.V. Krishna, M.R Babu and E.Ariwa:, "Global Trends in computing and communication system," Springer Berlin Heidelberg, pp.347-356, Fourth 2012.
- [3] "PAPR reduction in OFDM systems using peak insertion ScienceDirect." [Online]. Available: <https://www.sciencedirect.com/science/article/pii/S143484111400329X>. [Accessed :28-Dec-2018].
- [4] A.I. Siddiq, "PAPR reduction in OFDM systems using peak insertion," *AEU-Int.J.Electron. Commun.*, Vol.69,no.2, pp.573-578, Feb.2015.
- [5] S.Fragiacomo, C.Matrakidis and J.J. O'Reilly "Multicarrier transmission peak-to-average power reduction using simple block code," *Electron.Lett.*, vol.34,no.10, pp.953-954, May 1998.
- [6] S.Yoo, S.Yoon, S.Y.Kim and I.Song, "A novel PAPR reduction scheme for OFDM systems: selective mapping of partial tones(SMOPT)," *IEEE Trans. Consum. Electron.*, vol.52,no.1, pp.40-43, Feb.2006.
- [7] S.H. Han and J.H. Lee, "PAPR reduction of OFDM signals using a reduced complexity PTS technique," *IEEE Signal Process.Lett.*, vol.11, pp.887-890, Nov. 2004.
- [8] D.W.Lim, J.S.No., C.W.Lim and H.Chung, "A new SLM OFDM scheme with low complexity for PAPR reduction" *IEEE Signal Process Lett.*, Vol.12,no.2, pp.93-96, Feb.2005.

Author's Profile



Rupesh Kumar is final year M.Tech student in the Department of Electronics And Communication Engineering at B I T, Bhopal, under RGPV, Bhopal. His areas of interest are in Digital Communication, MIMO Technology and Electronic circuit design. He had also Published a research paper during B.Tech.



Prof. Gulab Singh Vaishya is Assistant Professor in the Department of Electronics And Communication Engineering at BIT, Bhopal, under RGPV, Bhopal. His areas of interest are in Microwave, Digital Communication and Radar Technology